

Battery Guard[®] 1000 (12v)

Part number: 00-01118-000



Description:

The Battery Guard[®] 1000 helps prevent "dead batteries". By disconnecting the battery load from the battery before it becomes too discharged, the Battery Guard[®] 1000 protects the battery from potential damage. It is designed to be used in vehicles with 12-volt electrical systems. The Battery Guard[®] 1000 is an improved and simplified solution to the well-recognized Intellitec Battery Guard[®] line of products. The heart of the system is the unique Battery Disconnect Relay (US Patent #4,628,289) that has been used by the transportation industry for over 25 years. This rugged, latching relay is capable of carrying heavy vehicle currents even though it requires no power to maintain its open or close positions. This single housing solution is easy to install and includes features such as automatic disconnect and reconnect, manual disconnect and reconnect, alarm output status and fault indication.

Block Diagram

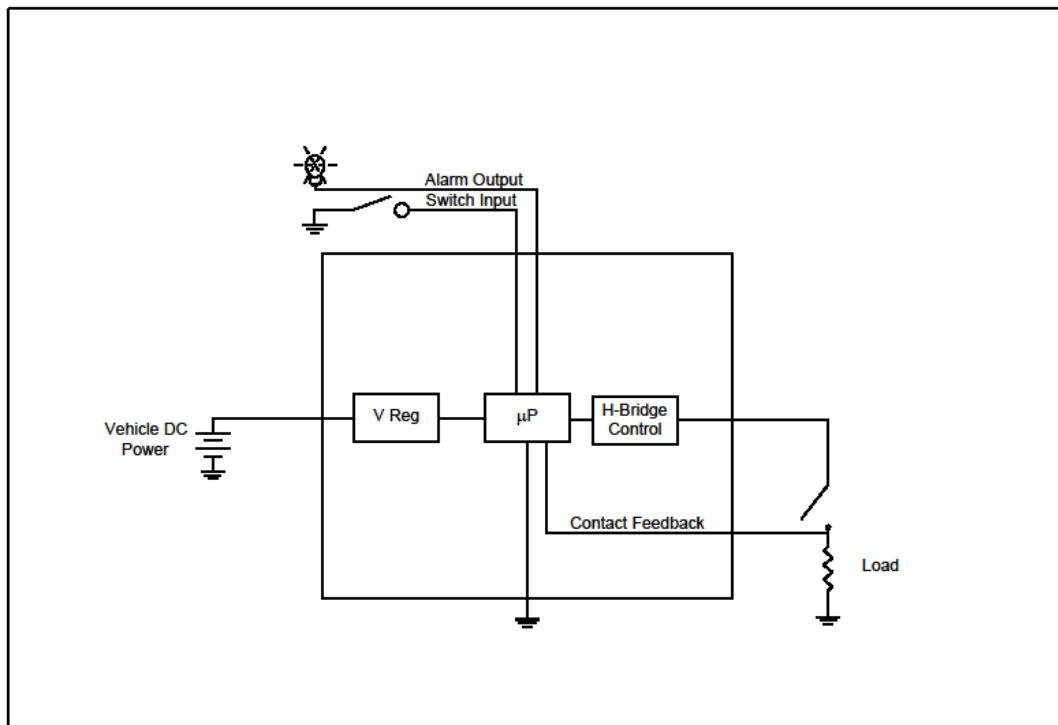



Product Features

- 100 A continuous load capacity
- Mechanically latching requires no current draw to maintain
- Factory configurable parameters
- Automatic low voltage disconnect and reconnect
- Disconnect and reconnect verification with automatic retry
- Momentary low-side switch input toggles between connected and disconnected state
- 300 mA high-side alarm output for indicating disconnected, reconnected and low voltage state
- Quick Connect terminals for easy wire installation

Environmental Specifications

Operating temp:	-20/50 deg C	(-24/122 deg F)
Storage temp:	-40/85 deg C	(-40/185 deg F)
Intrusion Rating:	None	
Agency approvals:	None	

Electrical Specifications	Unit	Min	Typ	Max
Operating supply voltage	V	6	12	18
Reverse supply voltage	V			-30
Quiescent Current Draw	mA		1	5

Mechanical Specifications	Unit	L x W x H
Housing:	Inch	3.0 x 3.5 x 3.75
	mm	76.2 x 88.9 x 95.25
Module Weight:	oz	9.0
	g	255.1

Available Accessory Items and Kits

100A Battery Guard® 1000 Kit: (Includes 00-01118-000, 11-01085-001, 11-01118-000, 11-01118-001)	10-01118-000
Battery Guard® 1000 Reset Switch:	11-01085-001
Battery Guard® 1000 Harness Extension (10ft):	11-01118-000
Battery Guard® 1000 Harness (10ft):	11-01118-001



Available Product Literature and Guides:

Brochure:	53-01118-000
Product Specification:	53-01118-001
User's Guide:	53-01118-100
Installation and Applications:	53-01118-200
Supporting Documents:	53-01118-300

Contact Information: www.intellitec.com

Intellitec Products, LLC 1485 Jacobs Road, De Land Florida, USA 32724
(386) 738-7307

