

# **BATTERY CONTROL CENTER - GAS/Metal Box**

## **SERVICE MANUAL**



### **Part Number 00-00287-000 Metal Box**

The **Battery Control Center** is a centralized power switching, fusing and distribution center. Power from the chassis and the coach batteries is fed into the Battery Control Center. The full power of both batteries is available within the box. The system consists of two (2) Battery Disconnect Relays, a coach battery charging circuit, an auxiliary start function to provide a "jump start" from the coach battery, an ignition solenoid and a fog light relay circuit.

#### **CAUTION:**

In advertent shorts inside this box could result in severe damage and/or injury.

**All servicing within this box should be done only by a qualified Service Technician.**

Tools required: Low current Test Light, Accurate Voltmeter (digital read-out preferred)

*To Remove Cover:* Turn each of the two quarter-turn fasteners until they are in the vertical position. Then, pull the bottom of the cover out. The cover will be retained by the plastic chain.

**Intellitec**

1485 Jacobs Rd.  
Deland, FL 32724  
386.738.7307

# BATTERY CONTROL CENTER - GAS/Metal Box

## SERVICE MANUAL

### **How The Battery Control Center Works**

#### **Battery Disconnect**

The Battery Disconnect relays are used to disconnect the batteries during periods of storage or during service. The disconnect relays operate by momentarily applying 12 volts to the solenoid coil in either of two directions, (+12 volts on the "S" terminal and ground on the "I" terminal for opening) and (+12 volts on the on the "I" terminal and ground on the "S" terminal for engaging the relay). The actuation voltage is supplied from the coach or chassis battery through F19. The voltage is supplied to the momentary switches mounted in the coach and then fed back to the relays in the box. (See *Battery Disconnect schematic, Figure 1*)

#### **Charging Circuit**

The charging circuit operates by sensing the ignition and coach battery voltage and closing the external isolator relay between the coach and chassis batteries, when the voltage on either battery goes above 13.3 volts for more than 14 seconds. If the ignition voltage falls below 12 volts for more than 4 seconds, the isolator relay will open, keeping all of the alternator's output available for the chassis functions. Should the coach battery's voltage drop below 12.8 volts for 4 seconds, the isolator relay will open, keeping all the converter's output available for coach functions.

(See *Charging Circuit/Aux Start schematic, Figure 2.*)

#### **Auxiliary Start**

The Auxiliary Start function is used to provide a "jump start" from the auxiliary battery in the event that the main battery does not have sufficient charge to start the engine. It operates by momentarily connecting the main and the auxiliary batteries together through the isolator relay. This function is accomplished by pressing the dash mounted switch, which applies 12 volts to the isolator relay coil. This power is supplied by fuse F17. (See *Charging Circuit/Aux Start schematic, Figure 2.*)

#### **Ignition Switched Power**

The ignition power is switched by three relays to supply power to the horn, the rear heater, the power windows and the power seat. The power for these relay coils comes from the ignition switch through J4, pin 11. (See *Charging Circuit/Aux Start schematic, Figure 2.*)

#### **Fog Light Relay**

The Fog Light relay supplies 12 volts to the fog lights, when the coach is so equipped. To operate the fog lights, 12 volts from a dash mounted fog light switch is applied to the relay's coil, through pin 12 of J4. The fog light's power comes from the main battery through fuse F13. It is switched by the relay and is routed from the printed circuit board through plug J4, pin 12. (See *Fog Light schematic, Figure 3.*)

# **BATTERY CONTROL CENTER - GAS/Metal Box**

## **SERVICE MANUAL**

### **Battery Disconnect**

#### **Both relays fail to operate.**

Both batteries may be dead. Check for voltage at the top and of F19, which is the feed from the batteries. (F19 is located at the top, center of the printed circuit board). The voltage on F19 should be at least 11 volts. If the voltage is less, charge one of the batteries. If the voltage is more than 11 volts, continue.

F19 may be blown. Using a test light, check for voltage at the bottom of F19. This voltage should be the same as at the top end. If the voltage is not the same, replace fuse F19.

Ground lead to switches may be open. Check for ground and 12 volts on the "I" and "S" terminals of the Disconnect Relay, while pressing the Battery Disconnect switch in the coach.

#### **One relay fails to operate.**

Wiring or switch may be faulty. To check the operation, have an assistant operate the Battery Disconnect switch to the "**use**" position from inside the coach. Check for voltage on the "I" terminal of the relay and the ground on the "S" terminal.

Disconnect Relay may be faulty. If at least 11 volts is available on the "I" or on the "S" terminal and the relay fails to operate, replace the relay.

#### **Chassis relay fails to operate.**

Ignition may be on. Check to be certain that the switched-ignition is 0 volts.

Interlock relay may be faulty. Check for 12 volt power feeding switch at plug J2 pin 8.

There may not be 12 volt power to the switch. If there is not 12 volts check fuse F19.

#### **Coach functions operate when coach is plugged in, but not from the battery.**

Circuit breakers feeding converter may be open. Reset circuit breakers in box.

# **BATTERY CONTROL CENTER - GAS/Metal Box**

## **SERVICE MANUAL**

### **Charging Circuit**

**Coach battery does not charge.**

The isolator relay may not be closing. Operate the engine at a high idle for at least twenty (20) seconds and check the chassis battery voltage. The voltage must be at least 13.3 volts before the isolator activates. If the voltage is less than 13.3 volts, check the alternator.

Check for voltage on the coil terminals of the isolator relay. If there is **no** voltage on the coil, replace the printed board. If there is voltage on the coil, check for voltage on the main terminals of the relay. If the voltages are different, replace the relay.

### **Auxiliary Start**

Fuse 17 may be blown. Check F17.

The coach battery may be dead. Charge battery.

The Isolator relay may be defective. Replace relay

Switch may be faulty. Check for 12 volts at J4 pin 2, while pushing switch. If there is not 12 volts, replace the switch.

### **Ignition Relay**

**The horn, the power window, the rear heater and the power seat fail to operate.**

Ignition relay may be faulty. On the relay check for 12 volt power at relay's terminals

Check for 12 volt power coming into printed circuit board on plug J4, pin 11.

Check for faulty wiring from the ignition switch.

Replace the ignition relay.

# BATTERY CONTROL CENTER - GAS/Metal Box

## SERVICE MANUAL

### Fog Lights

**Fog Lights fail to operate.**

Bulbs are burned out. Replace.

Ignition is not on.

No 12 volt power. Check fuse F13.

No power from the fog light switch. Check for voltage at J4, pin 12.

No 12 volt power to fog lights. Check for voltage at J4, pin 9.

Fog light relay has failed. Replace printed circuit board.

### Fuses

The fuses used in the Battery Control Center are standard, plastic "ATO", blade (automotive) type. There are 20 positions for fuses on the board. These are fed from four main sources, the Disconnect-Switched Chassis Battery, the Ignition-Switched Chassis Battery, the Disconnect-Switched Coach Battery and the Coach Battery. The 20 fuses and their size are as follows:

#### Disconnect-Switched Chassis Battery

			<u>Pin-Out</u>
Spare	F1	15 Amp	J9
Spare	F2	15 Amp	J10
Step Motor	F3	25 Amp	J5-1
Step Switch	F4	5 Amp	J5-2
LP Detector	F5	5 Amp	J5-3

#### Ignition-Switched Chassis Battery

Ignition Signal	F6	7.5 Amp	J5-4
Power Seat	F7	15 Amp	J5-5
Rear Heater	F8	15 Amp	J5-6
Power Window	F9	20 Amp	J5-7
Horn/Leveling Jacks	F10	15 Amp	J5-8
Spare	F11	15 Amp	J11
Spare	F12	15 Amp	J12

<u>Fog Light</u>	F13	15 Amp	J4-9
------------------	-----	--------	------

**Intellitec**

1485 Jacobs Rd.  
Deland, FL 32724  
386.738.7307

# BATTERY CONTROL CENTER - GAS/Metal Box

## SERVICE MANUAL

### Disconnect-Switched Coach Battery

			Pin-Out
Spare	F14	15 Amp	J6
LP Detector	F15	5 Amp	J4-4
Radio Switch	F16	10 Amp	J4-1

### Coach Battery

Auxiliary Start	F17	5 Amp	J4-2
Solar Panel	F18	5 Amp	J4-3
Battery Disconnect	F19	5 Amp	J2-7

# BATTERY CONTROL CENTER - GAS/Metal Box

## SERVICE MANUAL

### Circuit Breakers

There are two 30 Amp, type III (manual reset), circuit breakers mounted in the box. They are connected to the Coach's battery through the Disconnect relay. These breakers are intended to connect to the converter and fuse panel within the coach.

### Plugs - Pins & Functions

#### J1 - 8 pin in-line (KK-156)

Pin	Function
1	Chassis BD "I" terminal
2	Chassis BD "S" terminal
3	Coach BD "S" terminal
4	Coach BD "I" terminal
5	Isolator Relay "hot" terminal
6	Isolator Relay ground terminal
7	Ignition Relay "hot" terminal
8	Ignition Relay ground terminal

#### J2 - 9 pin Mate-N-Lok Mating Housing Amp 1-480706-0

Pin	Function	Fuse
1	Chassis BD "I" terminal	
2	Chassis BD "S" terminal	
3	Coach BD "S" terminal	
4	NC	
5	NC	
6	Coach BD "I" terminal	
7	Coach BD power, (Aux. Bat.)	F19
8	Chassis BD power, (Aux. Bat.), ignition switch	
9	BD Relay ground	

# BATTERY CONTROL CENTER - GAS/Metal Box

## SERVICE MANUAL

### Circuit Breakers

### Plugs - Pins & Functions

#### J4 - 12 pin Mate-N-Lok Mating Housing AMP 1-480708-0

Pin	Function	Fuse
1	Radio Switch	F16
2	Aux Start Switch	F17
3	Solar Panel	F18
4	L. P. Det. (Aux.)	F15
5	NC	
6	Ground	
7	NC	
8	NC	
9	Fog Lights	F13
10	Aux Start Relay Coil	
11	Ignition Relay Coil	
12	Fog Light Relay Coil	

#### J5 - 8 pin Mate-N-Lok Mating Housing AMP 640586-1

Pin	Function	Fuse
1	Step Motor	F3
2	Step Switch	F4
3	L. P. Det. (Chassis)	F5
4	Ignition Signal	F6
5	Power Seat	F7
6	Rear Heater	F8
7	Power Window	F9
8	Horn/Leveling Jacks	F10



# BATTERY CONTROL CENTER - GAS/Metal Box

## SERVICE MANUAL

### BATTERY DISCONNECT SCHEMATIC

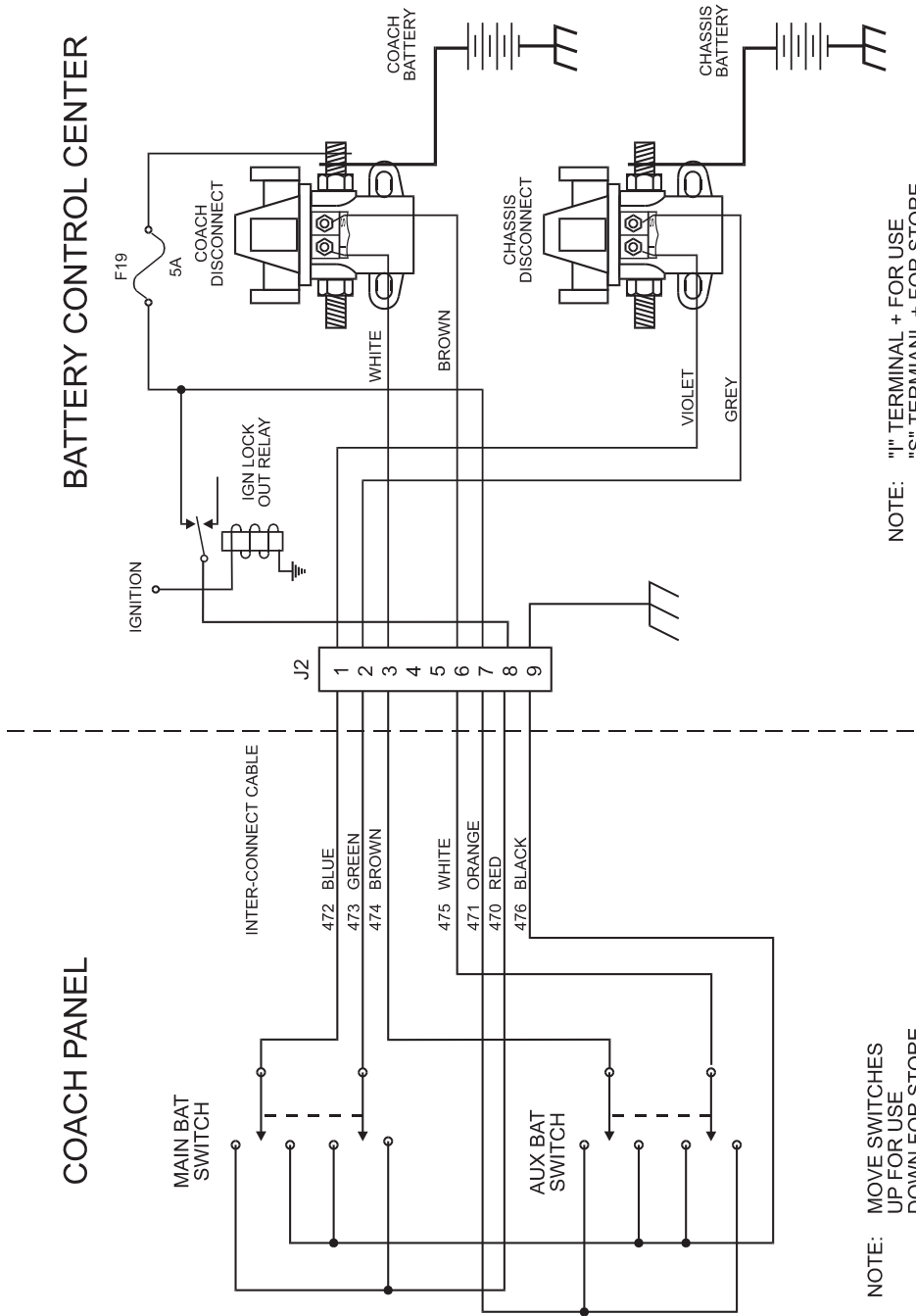

NOTE: MOVE SWITCHES UP FOR USE DOWN FOR STORE

NOTE: "I" TERMINAL + FOR USE "S" TERMINAL + FOR STORE

FIGURE 1

# BATTERY CONTROL CENTER - GAS/Metal Box

## SERVICE MANUAL

### ISOLATOR/AUX START SCHEMATIC

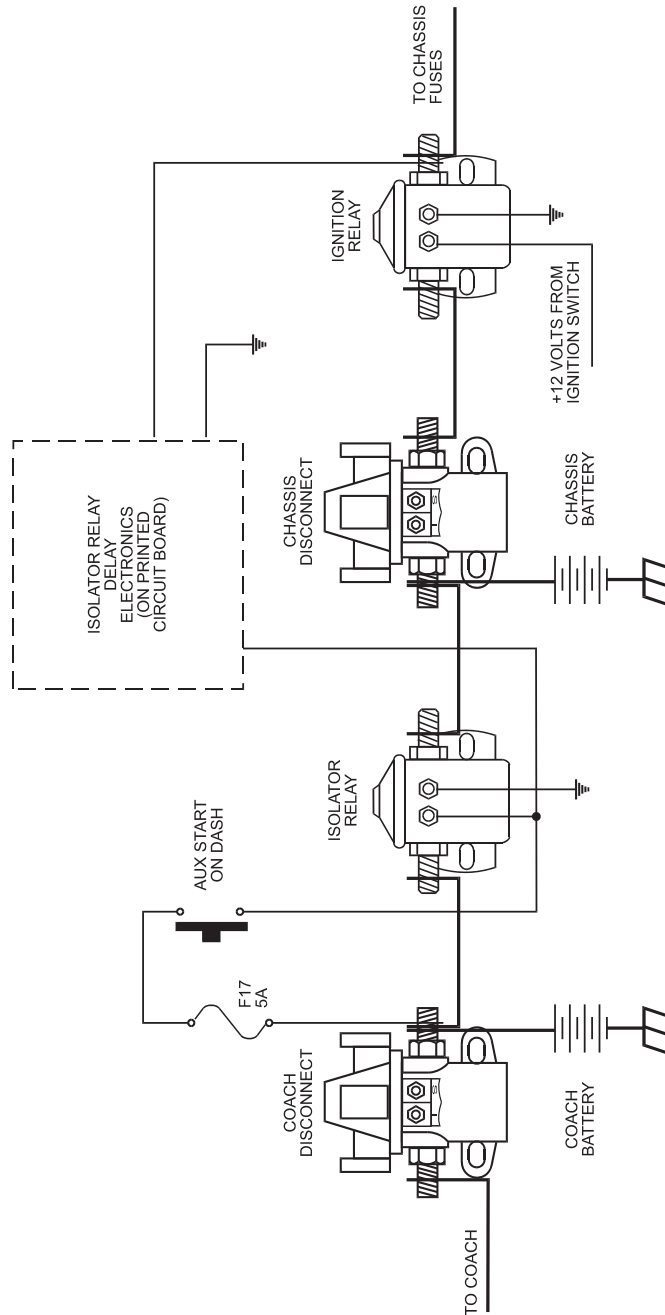

FIGURE 2

# BATTERY CONTROL CENTER - GAS/Metal Box

## SERVICE MANUAL

### FOG LIGHT RELAY SCHEMATIC

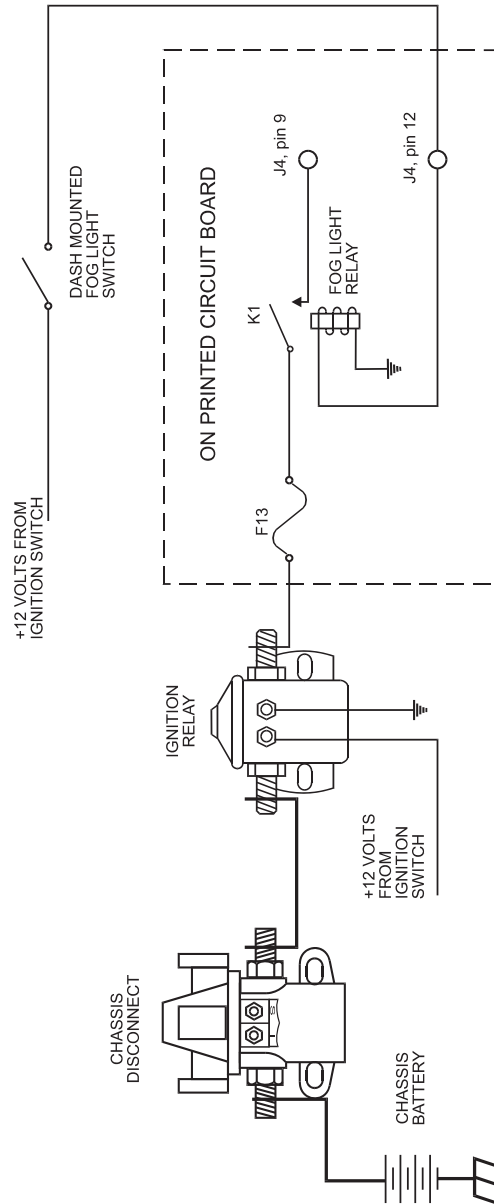

FIGURE 3

# **BATTERY CONTROL CENTER - GAS/Metal Box**

## **SERVICE MANUAL**

**Intellitec**

1485 Jacobs Rd.  
Deland, FL 32724  
386.738.7307