

MIRROR WINDOW CONTROLLER™

SERVICE MANUAL

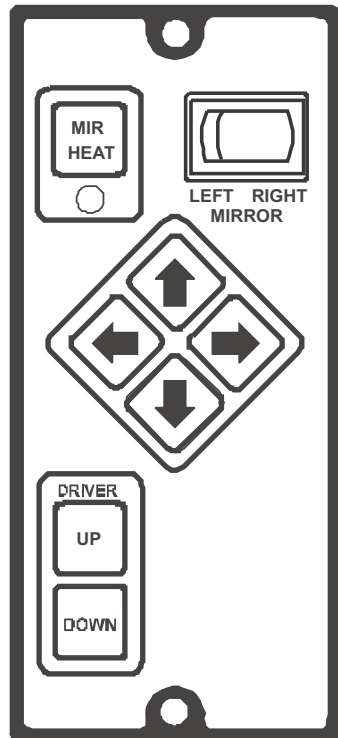

SINGLE

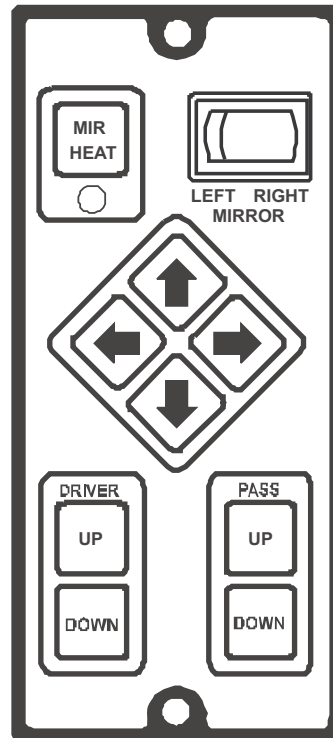

DUAL

CAUTION:

Service of the Mirror / Window Controller should be done only by a qualified Service Technician. Inadvertent shorts in and around the Mirror / Window Controller could result in severe damage and/or injury.

TOOLS REQUIRED:

Low current Test Light, Accurate Voltmeter (digital read-out preferred)

Intellitec

1485 Jacobs Rd.
Deland, FL 32724
386.738.7307

MIRROR WINDOW CONTROLLER™

SERVICE MANUAL

MIRROR POSITION

The mirror position is controlled by two electric motors mounted inside the mirror head; one for up/down and one for right/left. These two motors share one common wire, therefore only three wires come from the mirror motors. The controller feeds power to these three wires, as required, to operate the motors to position the mirror as desired.

When the mirror is at rest, all three leads are grounded through the relays. To position the mirror, the proper leads are switched to +12 Volts to run the motors in the proper direction.

The table below shows the voltages used to move the mirror:

Direction	WHT Wire	YEL Wire	YEL Wire
UP	GND	GND	+12V
DOWN	+12V	+12V	GND
LEFT	+12V	GND	GND
RIGHT	GND	+12V	+12V
AT REST	GND	GND	GND

Motor Wires:

Right-Left White
Common Yellow
Up-Down Black

Note: Pressing more than one direction switch at a time may cause the mirror to go in indeterminate directions. This will not cause any other problems. (See *Mirror Motor Schematic, Figure 1*)

Problem

Both mirrors fail to operate.

Possible Cause / Solution

No or low 12 volts feeding the panel.
Check power coming to panel at J2, pin 9.

Board mounted circuit breaker has failed. Check for power at both sides of board mounted, 6 Amp circuit breaker. If breaker has failed, replace breaker.

Check for proper voltages from controller. If incorrect, replace Controller.

Intellitec

1485 Jacobs Rd.
Deland, FL 32724
386.738.7307

MIRROR WINDOW CONTROLLER™

SERVICE MANUAL

MIRROR POSITON (continued)

Problem

Possible Cause / Solution

One mirror fails to operate.

Check for proper voltages from controller. If correct, mirror has failed. If incorrect, replace controller.

Check wiring to mirror.

Both mirrors fail to operate in one direction.

Controller has failed. Replace controller.

MIRROR HEAT

The mirrors are electrically heated to provide defrosting in cold weather. Pressing the mirror heat button turns on the mirror heat. The LED on the panel indicates the heat circuit is on. Another press turns off the heat. If the heat is left on for more than five minutes, a timer automatically turns off the heaters. The heat goes off when the ignition is turned off. It will be off when the ignition is turned on again.

12 Volts is applied to one side of the mirror heater from the board-mounted, 6 Amp, circuit breaker. The other side of the heater is connected to ground through a solid-state switch in the controller.
(See *Mirror Heat Schematic, Figure 2*)

Problem

Possible Cause / Solution

Both mirrors fail to heat.

No or low 12 volts feeding the panel.
Check power coming to panel at J2, pin 9.

Board mounted circuit breaker has failed. Check for power at both sides of board-mounted, 6 Amp, circuit breaker. If breaker has failed, replace breaker.

Check for switched ground at controller J2, pin 2.

One mirror fails to heat.

Mirror heater has failed, Replace mirror.

Wiring has failed. Check wiring to mirror.

Heat will not go off.

Controller has failed. Replace controller.

Intellitec

1485 Jacobs Rd.
Deland, FL 32724
386.738.7307

MIRROR WINDOW CONTROLLER™

SERVICE MANUAL

DRIVERS WINDOW CONTROL

The driver's window is controlled by applying 12 volts to one of two wires of the window motor. This is done in the controller with a pair of relays. Both motor leads are connected to ground when the motor is at rest. (See *Mirror Control Schematic, Figure 3*)

Problem

Possible Cause / Solution

Window will not operate.

No or low 12 volts feeding the panel.
Check power coming to panel at J2, pin 9.

Board mounted 10 Amp circuit breaker has failed. Using test light, check for 12 volts on both sides of circuit breaker. If breaker has failed, replace breaker.

Check voltages at motor wires. If correct, window motor has failed. Replace motor.

PASSENGER WINDOW

The passenger window is controlled by applying 12 volts to one of two window motor wires. This is done in the passenger window controller with a pair of relays. Both motor leads are connected to ground when the motor is at rest. A pair of wires connects to ground when the motor is at rest. A pair of wires connects the relay coils to the two switches on the driver's side panel. Connecting either of these two wires to ground will operate the passenger window. (See *Passenger Window Control Schematic, Figure 3*)

Problem

Possible Cause / Solution

Window will not operate.

No or low 12 volts feeding the panel.
Check power coming to panel at J2, pin 9.

Board mounted 10 Amp circuit breaker has failed. Using test light, check for 12 Volts on both sides of circuit breaker. If breaker has failed, replace breaker.

Check voltages at motor wires. If correct, window motor has failed. Replace motor.

Window will not operate from driver's side.

Using a voltmeter, measure for 12 volts at J2, Pins 6 & 7. If 12 volts is missing, check wiring.

Check wiring to driver's side.

Intellitec

1485 Jacobs Rd.
Deland, FL 32724
386.738.7307

MIRROR WINDOW CONTROLLER™

SERVICE MANUAL

PLUGS -Pins & Functions

J1 *2 pin, Mate-n-Lok* *Mating Housing*

<u>Pin</u>	<u>Function</u>
1	Window Motor -
2	Window Motor +

J2 *9 pin, Mate-n-Lok* *Mating Housing* *AMP 1-480706-0*

<u>Pin</u>	<u>Function</u>
1	Passenger Mirror Heat +12 Volts
2	Passenger Mirror Heat
3	Passenger Mirror left-right (White)
4	Passenger Mirror Common (Yellow)
5	Passenger Mirror Up-Down (Black)
6	Passenger Window Up
7	Passenger Window Down
8	Power Ground
9	+12 Volt Power Input

P1 *6 pin Mate-n-Lok (Driver's side plug)* *Mating Housing*

<u>Pin</u>	<u>Function</u>	<u>Board Connection</u>	<u>Wire Color</u>
1	N/C		
2	Mirror Heat +12 Volts	J3	Red
3	Mirror Heat	J4	Green
4	Mirror Motor left-right	J5	White
5	Mirror Motor Common	J6	Yellow
6	Mirror Motor Up-Down	J7	Black

MIRROR WINDOW CONTROLLER™

SERVICE MANUAL

Figure 1
MIRROR MOTOR SCHEMATIC

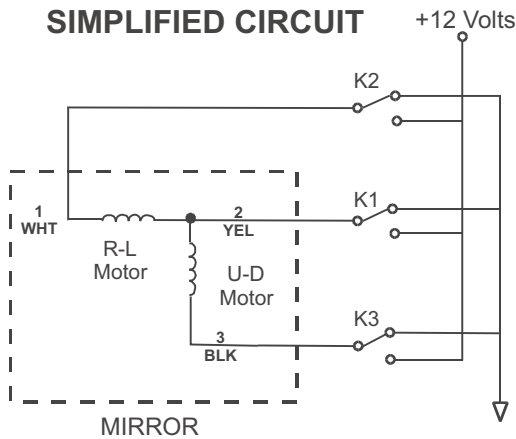

MIRROR DIRECTION VOLTAGE TABLE

	WHT	YEL	BLK
UP	GND	GND	+12V
DOWN	+12V	+12V	GND
LEFT	+12V	GND	GND
RIGHT	GND	+12V	+12V

MIRROR MOTOR CIRCUIT

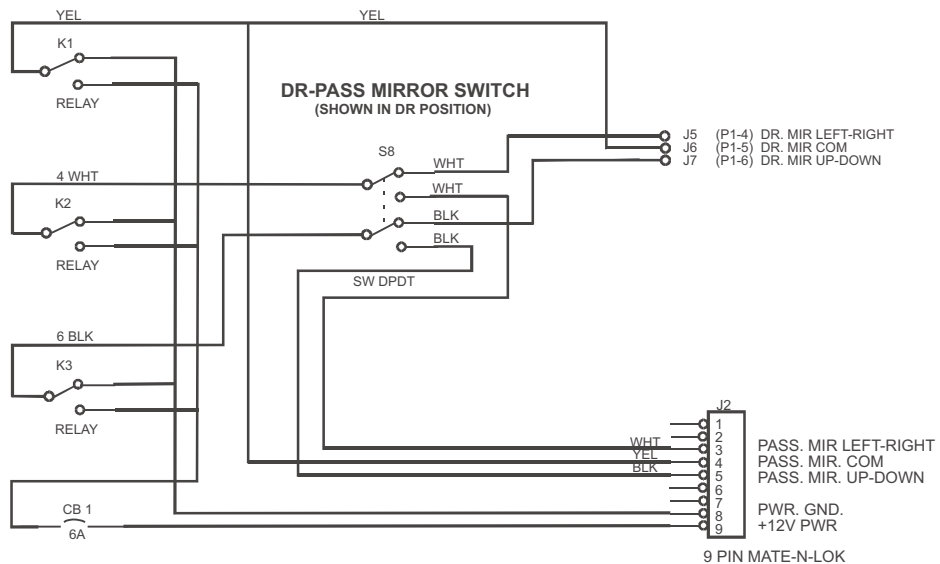

MIRROR WINDOW CONTROLLER™

SERVICE MANUAL

Figure 2 MIRROR HEAT SCHEMATIC

SIMPLIFIED CIRCUIT

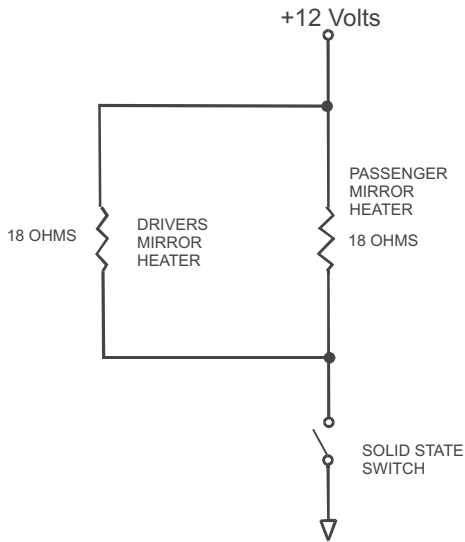

MIRROR HEATER CIRCUIT

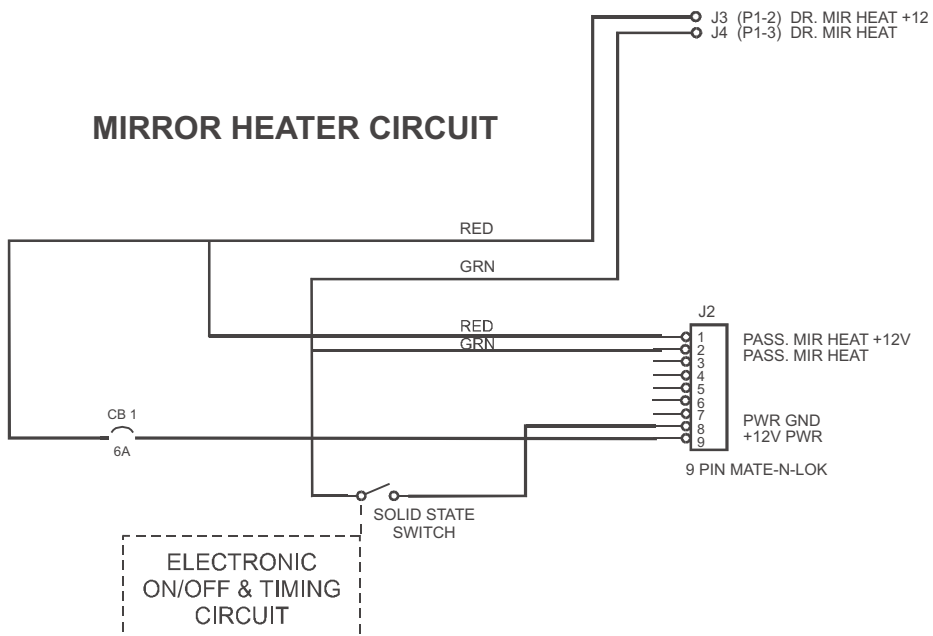

MIRROR WINDOW CONTROLLER™

SERVICE MANUAL

Figure 3
PASSENGER WINDOW CONTROL SCHEMATIC

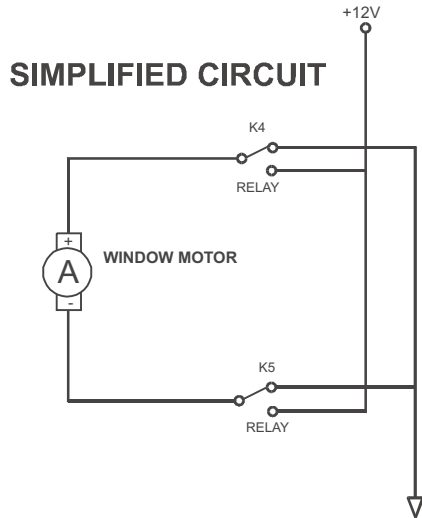

WINDOW MOTOR CIRCUIT

