

# Battery Control Center

Intellitec's **Battery Control Center™** is a centralized power switching, fusing and distribution center designed for motorhomes. The **Battery Control Center™** including battery isolation, charging, and connectorized fuse block, was specifically designed to fit in tight spaces under the hood. The system consists of two (2) Battery Disconnect Relays, a bi-directional battery charging circuit, an auxiliary start function to provide a "jump start" from the auxiliary battery, ignition power switching, and a fog light relay circuit. It is housed in a high impact plastic enclosure to protect the circuit components and keep them like new for years of operation.

Installation is made easy by the incorporation of battery cable clamps eliminating the need to terminate the battery cables. The branch circuits are fed out through AMP Mate - N - Lok connectors.

The unit is mounted to the vehicle with four mounting feet supplied with the unit. These feet can be attached to the unit in eight different locations to accommodate nearly any mounting configuration. The cover of the unit snaps off and on for easy service of the fuses should that ever be necessary. Each fuse is labeled in the box to make circuit identification a simple matter.



Part No. 00-00524-100

Following are the important features included in this system:

**Bi-Directional Battery Charging** - provides charging of both batteries if either is being charged. The Auxiliary battery is charged from the engine alternator and the Main battery is charged from the converter when the coach is plugged into shore power.

**Auxiliary Start** - provides a "jump start" from the auxiliary battery in the event that the main battery does not have sufficient charge to start the engine.

**Ignition Switched Power** - circuits are switched by three relays to supply power to the horn, the rear heater, the power windows and the power seat.

**Fog Light Relay** - supplies 12 volts to the fog lights, when the coach is so equipped, allowing operation of the fog lights.

**Circuit Breakers** - conveniently located near the front, at the bottom of the box. These circuit breakers protect the wiring between the Auxiliary battery and the converter. These breakers have manual reset buttons that pop out when they are tripped.

 **Intellitec**  
1485 Jacobs Rd.  
Deland, FL 32724  
386.738.7307

P/N 53-00524-000 Rev. C 032619

# Battery Control Center

## SPECIFICATIONS

Part Number: 00-00524-000  
 Standby Current: Less than 1 milliamp  
 Ambient Temperature Range: -40C to +85C  
 Normal Input Voltage Range: 10 to 18 volts  
 Short Term Over Voltage Protection: +26 volts  
 Reverse Voltage Protection: - 300 volts  
 Positive Voltage Spike Protection: +150 volts  
 Operating Environment:  
 Under hood, out of direct weather

## FUSES

### Disconnect-Switched Main Battery

Fuse No.	Function	Fuse Size (Max.)
F20	Spare	15 Amp
F21	Spare	15 Amp
F1	Spare	15 Amp
F2	Spare	15 Amp
F3	Step Motor	25 Amp
F4	Step Switch	15 Amp
F5	LP Detector	5 Amp
F7	Power Seat	15 Amp

### Ignition-Switched Main Battery

Fuse No.	Function	Fuse Size (Max.)
F6	Ignition Signal	7.5 Amp
F8	Rear Heater	15 Amp
F9	Power Window	15 Amp
F10	Horn/Leveling Jacks	15 Amp
F11	Spare	15 Amp
F12	Spare	15 Amp
F22	Spare	15 Amp
F23	Spare	15 Amp

### Fog Light

F13		15 Amp
-----	--	--------

### Disconnect-Switched Auxiliary Battery

F14	Spare	15 Amp
F15	LP Detector	5 Amp
F16	Radio Switch	10 Amp

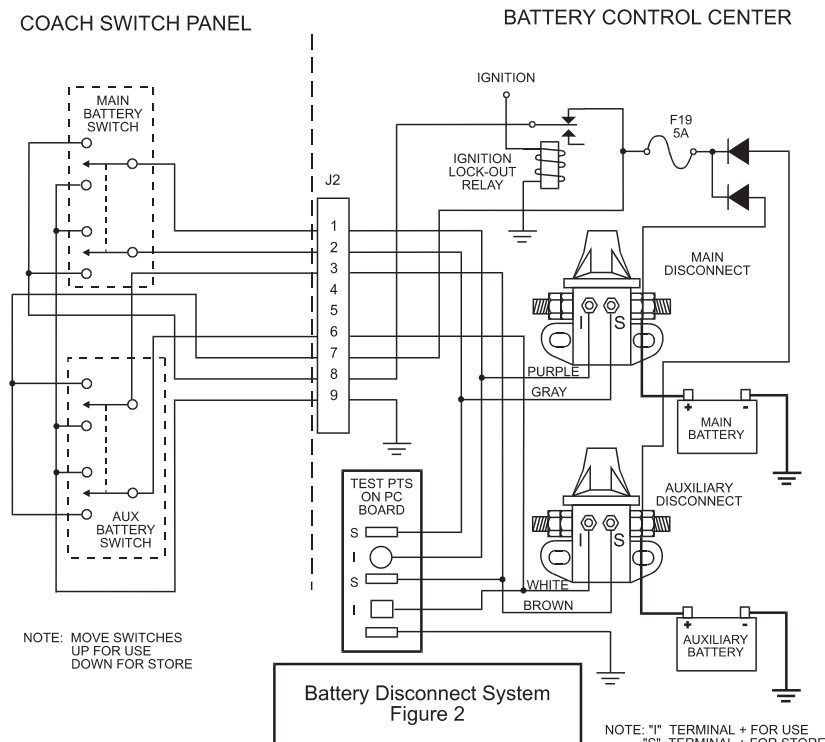

 **Intellitec**  
 1485 Jacobs Rd.  
 Deland, FL 32724  
 386.738.7307

P/N 53-00524-000 Rev. C 032619