

BATTERY CONTROL CENTER - MINI DIESEL

SERVICE MANUAL



Part Number 00-00606-100

Product Description

The Battery Control Center is a centralized power switching, fusing and distribution center. Power from the Main and the Auxiliary batteries is fed into the Battery Control Center. The full power of both batteries is available within the box. The system consists of two (2) Battery Disconnect Relays, a bi-directional battery charging circuit, an auxiliary start function to provide a "jump start" from the Auxiliary battery, ignition power switching and a fog light relay circuit.

CAUTION:

All servicing of the Battery Control Center should be done only by a qualified Service Technician. Inadvertent shorts inside the Battery Control Center could result in severe damage and/or injury.

TOOLS REQUIRED: Low current Test Light, Accurate Voltmeter, (digital read-out preferred).

TO REMOVE COVER: Gently lift the cover catches, located on each side of the box, and pull them outward and towards yourself. The cover may then be lowered to allow easy access to the fuses and circuitry.

Intellitec

1485 Jacobs Rd.
Deland, FL 32724
386.738.7307

BATTERY CONTROL CENTER - MINI DIESEL

SERVICE MANUAL

How The Battery Control Center Works

Battery Disconnect -

The Battery Disconnect relays are used to disconnect the batteries during periods of storage, or during service. The disconnect relays operate by momentarily applying 12 volts to the solenoid coil in either of two directions, (+12 volts on the "S" terminal and ground on the "I" terminal for opening) and (+12 volts on the "I" terminal and ground on the "S" terminal for engaging). The actuation voltage is supplied from the highest voltage of either the Auxiliary or Main battery through F19. The voltage is supplied to the momentary switches mounted in the coach and then fed back to the relays in the box. (See Battery Disconnect schematic, Figure 2).

Charging Circuit -

The charging circuit, (which utilizes an isolator solenoid to connect the two batteries together for charging) will charge both batteries if either battery is being charged. It operates by sensing the voltage on the Main and Auxiliary batteries. If either voltage goes above 13.3 volts (the minimum necessary to fully charge a battery) for more than 14 seconds, the isolator solenoid will pull in, charging both batteries. If, while the ignition is on, the voltage falls below 12 volts for more than 4 seconds, the isolator relay will open, keeping all of the alternator's output available for the chassis functions. If the ignition is off and the Auxiliary battery voltage should drop below 12.8 volts (voltage of a fully charged battery) for 4 seconds, the isolator relay will open, preventing the coach loads from discharging the main battery. (See Charging Circuit/Aux Start schematic, Figure 3).

Auxiliary Start -

The Auxiliary Start function is used to provide a "jump start" from the auxiliary battery in the event that the Main battery does not have sufficient charge to start the engine. It operates by momentarily connecting the Main and the Auxiliary batteries together through the isolator relay. This function is accomplished by pressing the dash mounted switch, which applies 12 volts to the isolator relay coil. The switch power is supplied by fuse F17. (See Charging Circuit/Aux Start schematic, Figure 3).

Ignition Switched Power -

The ignition circuits are switched by three relays, K1, K2, and K4, to supply power to the horn, rear heater, power windows and the power seat. The power for these relay coils comes from the ignition switch through J4, pin 11. (See Charging Circuit/Aux Start schematic, Figure 3). Each of the ignition relays is rated at 30 Amps, therefore the sum of the total continuous currents through relay K2, which includes fuse F6 (J5, pin 4)+F8 (J5, pin 6), must not exceed 30 Amps. In like manner, the sum of the total continuous currents through relay K1 which includes fuse F9 (J5, pin 7)+F10 (J5, pin 8)+F11 (J11) must not exceed 30 Amps, and the sum of the total continuous currents through relay K4 which includes fuse F12 (J12)+F22 (J17)+F23 (J18) must not exceed 30 Amps.

Fog Light Relay -

The Fog Light relay supplies 12 volts to the fog lights, when the coach is so equipped. To operate the fog lights, 12 volts from the ignition is fed to a dash mounted fog light switch and is applied to the relay's coil, through pin 12 of J4. The fog light's power comes from the Main battery through fuse F13. It is switched by the relay and is routed from the printed circuit board through plug J4, pin 9. (See Fog Light schematic, Figure 4).

Circuit Breakers -

There are two 30 Amp circuit breakers, located near the front at the bottom of the box, that are used to protect the wiring between the Auxiliary battery and the converter. These breakers have manual reset buttons that pop out when they are tripped (See Figure 5)

Intellitec

1485 Jacobs Rd.
Deland, FL 32724
386.738.7307

BATTERY CONTROL CENTER - MINI DIESEL

SERVICE MANUAL

TROUBLE SHOOTING

The Battery Control Center is built in two layers, the printed circuit board and the relays. The box has been designed so that nearly ALL trouble shooting can be done without the removal of the printed circuit board. Read and understand the trouble shooting procedure first before EVER removing the printed board. The printed circuit board must be removed to repair the relays on the lower level.

Checking Fuses

Once the outer box cover has been removed, ALL the fuses in the box are located on the printed circuit board and are easily visible for testing and replacement. The fuses can be checked either visually, or with a test light.

To check the fuses visually: Remove the suspected fuse using the fuse tool supplied in the box and examine for damage to the fusing element.

To check using a test light: Ground the test light to the test ground terminal, J20, provided on the board. (See printed circuit board illustration, Figure 1) **Note: This ground terminal should never be used for any other purpose.** Check for power on both sides of the fuse. If applicable, make sure Battery Disconnect Relays and fog light switches, are on when checking fuses.

Checking the Battery Disconnects

The Battery Disconnect relay terminals are available at test points on the printed circuit board, making it unnecessary to remove the board for testing. These test points are located near the left edge of the board and are labeled. Each "S" terminal is available through a 1/4" spade connector so that the test light can be clipped to it. There is a ground terminal at the bottom of the group that can be used for a test light ground.

To engage a relay, momentarily apply +12 volts to the "I" terminal, TP1 or TP2, and the "S" terminal, J19 or J21, is grounded. To open the relay, momentarily apply +12 volts to the "S" terminal and the "I" terminal is grounded.

Isolator Relay

A push button to test the isolator relay is provided on the board to manually actuate the relay. It is located near the upper right corner of the board and labeled "AUX START". (See Figure 1) The coach must be unplugged and the engine and generator need to be off for at least ten minutes, to allow the isolator electronics to turn off the relay drive. Pressing this button should close the isolator relay, which can be detected by the clicking sound of the relay.

Circuit Breakers

The converter circuit breakers, which are in parallel, carry the current between the Auxiliary battery and the converter. If the coach is not being supplied 120 volts AC, the current is flowing from the battery to the converter. If the coach is being supplied 120 volts AC, the converter is usually charging the batteries and the current will flow from the converter to the batteries. If there is a fault or overload between the converter and the batteries, the circuit breakers will open as indicated by the reset buttons being popped out. To reset the breakers, turn off the 12 loads and push the buttons in until they latch.

BATTERY CONTROL CENTER - MINI DIESEL

SERVICE MANUAL

PRINTED CIRCUIT BOARD REMOVAL

In the event that the printed circuit board needs to be removed, the following procedure should be followed.

- 1) Remove the negative wires from both batteries to prevent injury to individuals and the equipment. Be sure that these wires stay clear of the battery posts. Remove power to the converter.
- 2) Remove the cover of the Battery Control Center to expose the board.
- 3) Pull chassis harness plugs from connectors, J2, J4, and J5.
- 4) Note the locations of wires connected to Faston connectors, J9 through J12, and J15 through J18, located along the lower edge of the board next to J5. It is best to write down the wire positions and colors so that they can be re-connected correctly.
- 5) Pull relay harness plug from J1.
- 6) Note the locations of wires connected to output Faston connectors, J6, J7, J8, and J13, located along the upper edge of the board. It is best to write down the wire positions and colors so that these wires can be re-connected correctly.
- 7) Remove the 1/4" hex head bolt located near the center-right side of the board.
- 8) Remove the four #8 hex head screws located in the four corners and center of the board.
- 9) Remove the board.

PRINTED CIRCUIT BOARD REPLACEMENT

Replace the board in the reverse order from the removal. Be sure to tighten the 1/4" hex head bolt going through the board, for it provides the power connection to the battery feed. Failure to properly tighten this bolt will lead to failure.

BATTERY CONTROL CENTER - MINI DIESEL

SERVICE MANUAL

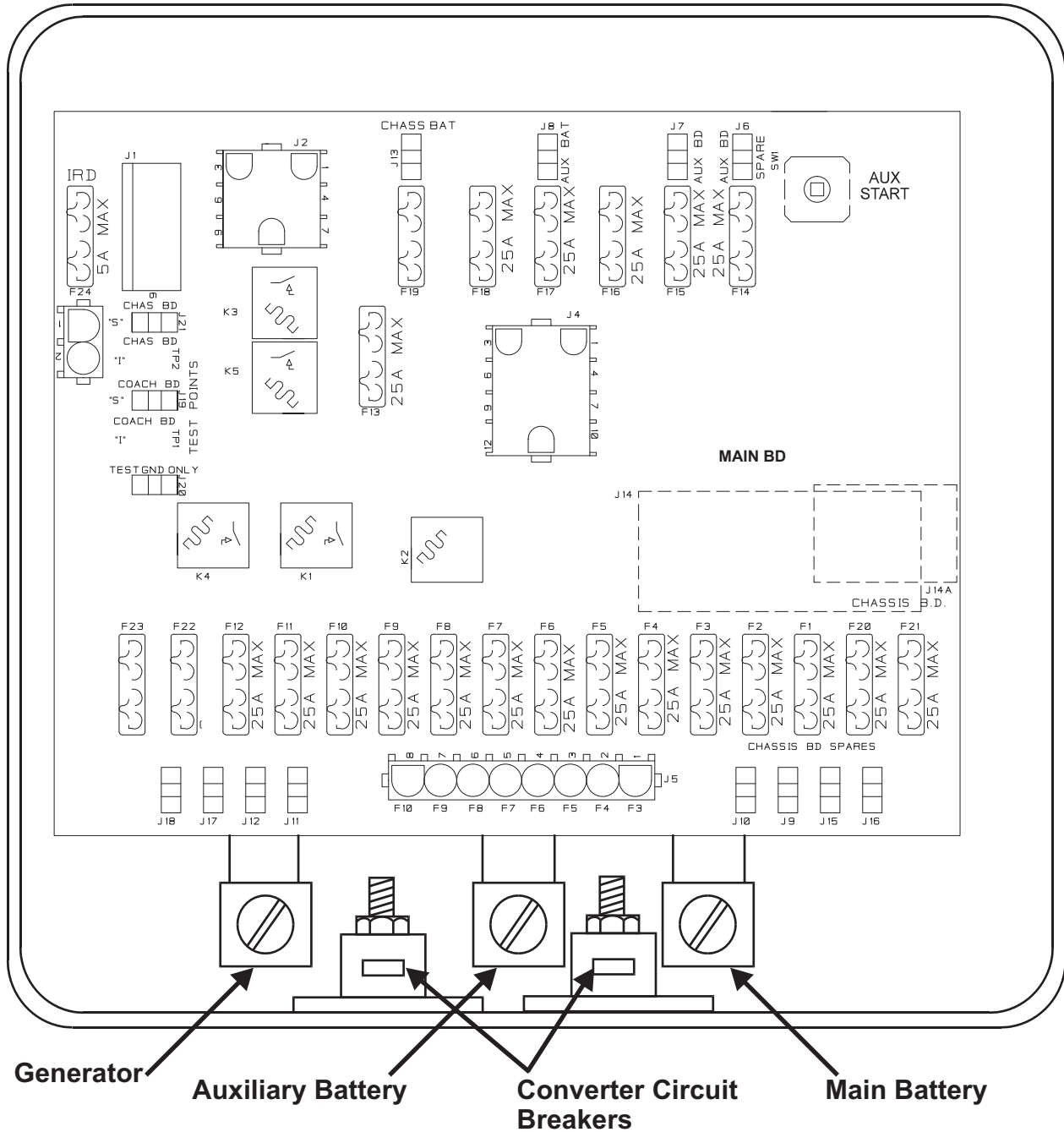

Pictorial View
Figure 1

Intellitec

1485 Jacobs Rd.
Deland, FL 32724
386.738.7307

BATTERY CONTROL CENTER - MINI DIESEL

SERVICE MANUAL

TROUBLE SHOOTING - Battery Disconnect

A. Both relays fail to operate.

1. Batteries may be dead. Check for voltage at the top end of F19 which is the feed from the higher of either the auxiliary or main battery. (F19 is located at the top left center of the printed circuit board). The voltage on F19 should be at least 11 volts. If the voltage is less, charge either battery. If the voltage is more than 11 volts, continue.
2. F19 may be blown. Check for voltage at the top of F19 using a test light. This voltage should be the same as at the bottom end. Replace fuse F19, if the voltage is not the same.
3. Ground lead to switches may be open. Check for ground and 12 volts on the "I" and "S" test points on the printed circuit board of the Disconnect Relay, while an assistant presses the Battery Disconnect switch in the coach.

B. One relay fails to operate.

1. Wiring or switch may be faulty. To check the operation, have an assistant operate the Battery Disconnect switch inside the coach. Check for voltage on the "I" and ground on the "S" terminal at the test points on the printed circuit board.
2. Disconnect Relay may be faulty. If at least 11 volts is available on the "I" or "S" terminal and the relay fails to operate, replace the relay.

C. Main battery relay fails to operate.

1. Ignition may be on. Check to be certain that the switched-ignition is 0 volts.
2. Interlock relay may be faulty. Check for 12 volt power feeding switch at plug J2 pin 8.
3. There may not be 12 volt power to the switch. If there is not 12 volts check fuse F19.

D. Coach functions operate when coach is plugged in, but not from the battery.

1. Circuit breakers feeding converter may be open. Reset circuit breakers in box.

BATTERY CONTROL CENTER - MINI DIESEL

SERVICE MANUAL

TROUBLE SHOOTING - Charging Circuit

A. Auxiliary battery does not charge.

1. The isolator relay may not be closing. Operate the engine at a high idle for at least twenty (20) seconds and check the chassis battery voltage. The voltage must be at least 13.3 volts before the isolator activates. Check the alternator, if the voltage is less than 13.3 volts.

Check for voltage on the coil terminal of the isolator relay. This voltage is available on J1-5. If there is **no** voltage on the coil, replace the printed board. If there is voltage on the coil, check for voltage between the main and auxiliary batteries. If the voltage is more than 0.1 volts replace the relay.

B. Main battery continues to drain.

1. Isolator relay may be bad. Check for voltage on the solenoid coil lead which is available on J1-5, when the engine is off. If there is no voltage, replace the relay.

C. Main battery doesn't charge from converter.

1. The converter is not putting out at least 13.3 volts. Check converter, turn off excess 12 volt loads if necessary.
2. Converter circuit breakers in Battery Control Center open. Reset breakers are located on lower edge of box.

Auxiliary Start

A. Auxiliary Start fails to operate.

1. Fuse 17 may be blown. Check F17.
2. The Auxiliary battery may be dead. Charge battery.
3. Isolator relay may be defective. To test the relay, press the "AUX START" switch on printed circuit board while measuring the voltage between the two batteries. (The isolator relay should "click" indicating that it is closing.) If the voltage is more than 0.1 volt, replace the relay.
4. Switch or wires may be faulty. Check for 12 volts at J4 pin 2, while pushing switch. If there is not 12 volts, check wiring, if OK, replace the switch.

BATTERY CONTROL CENTER - MINI DIESEL

SERVICE MANUAL

TROUBLE SHOOTING - Ignition Relay

A. The horn, the electric step, power window, the rear heater or the power seat fail to operate.

1. Check for 12 volt ignition power coming into printed circuit board on plug J4, pin 11.
2. Check respective fuse.
3. Check for faulty wiring from the ignition switch.
4. Replace the printed circuit board.

Fog Light Relay

A. Fog Lights fail to operate.

1. Bulbs are burned out. Replace.
2. Ignition is not on.
3. No 12 volt power. Check fuse F13.
4. No power from the fog light switch. Check for voltage at J4, pin 12.
5. No 12 volt power to fog lights. Check for voltage at J4, pin 9.
6. Fog light relay has failed. Replace printed circuit board.

BATTERY CONTROL CENTER - MINI DIESEL

SERVICE MANUAL

FUSES

The fuses used on the Battery Control Center are standard, plastic "ATO", blade (automotive) type. There are 23 positions for fuses on the board. These are fed from five main sources, the Disconnect-Switched Main Battery, Ignition-Switched Main Battery, Disconnect-Switched Auxiliary Battery and the Auxiliary Battery.

The 23 fuses and their size are as follows:

<u>Disconnect-Switched Main Battery</u>			<u>Connector Pin-Out</u>
Spare	F20	15 Amp	J15
Spare	F21	15 Amp	J16
Spare	F1	15 Amp	J9
Spare	F2	15 Amp	J10
Step Motor	F3	25 Amp	J5-1
Step Switch	F4	5 Amp	J5-2
LP Detector	F5	5 Amp	J5-3
Power Seat	F7	15 Amp	J5-5

Ignition-Switched Main Battery

Ignition Signal	F6	7.5 Amp	J5-4
Rear Heater	F8	15 Amp	J5-6
Power Window	F9	20 Amp	J5-7
Horn/Leveling Jacks	F10	15 Amp	J5-8
Spare	F11	15 Amp	J11
Spare	F12	15 Amp	J12
Spare	F22	15 Amp	J17
Spare	F23	15 Amp	J18

NOTE: Each of the ignition relays is rated at 30 Amps, therefore care must be exercised when substituting fuses or adding additional loads. The sum of the total continuous currents through relay K2, which includes fuse F6 (J5, pin 4)+F8 (J5, pin 6), must not exceed 30 Amps. In like manner, the sum of the total continuous currents through relay K1A which includes fuse F9 (J5, pin 7)+F10 (J5, pin 8)+F11 (J11) must not exceed 30 Amps, and the sum of the total continuous currents through relay K1B which includes fuse F12 (J12)+F22 (J17)+F23 (J18) must not exceed 30 Amps.

<u>Fog Light</u>	F13	15 Amp	J4-9
------------------	-----	--------	------

Disconnect-Switched Auxiliary Battery

Spare	F14	15 Amp	J6
LP Detector	F15	5 Amp	J4-4
Radio Switch	F16	10 Amp	J4-1

Intellitec

1485 Jacobs Rd.
Deland, FL 32724
386.738.7307

BATTERY CONTROL CENTER - MINI DIESEL

SERVICE MANUAL

FUSES (CONT'D)

<u>Auxiliary Battery</u>			<u>Connector Pin-Out</u>
Auxiliary Start	F17	5 Amp	J4-2
Solar Panel	F18	5 Amp	J4-3
 <u>Battery Disconnect</u>			
Battery Disconnect Relay	F19	5 Amp	J2-7

CIRCUIT BREAKERS

There are two, 30 Amp type III (manual reset) circuit breakers mounted in the box. They are connected to the Auxiliary battery through the Disconnect relay. These breakers are intended to connect to the converter and fuse panel within the Auxiliary. These circuit breakers are located at the bottom of the box, near the front edge. To reset the breakers, press the buttons on the ends.

PLUGS - PINS & FUNCTIONS

J1 - 8 pin in-line (KK-156)

Pin	Function
1	Main BD "I" terminal
2	Main BD "S" terminal
3	Auxiliary BD "S" terminal
4	Auxiliary BD "I" terminal
5	Isolator Relay "HOT" terminal
6	Isolator Relay GROUND terminal

BATTERY CONTROL CENTER - MINI DIESEL

SERVICE MANUAL

PLUGS - PINS & FUNCTIONS (Cont'd)

J2 - 9 pin Mate-N-Lok Mating Housing Amp 1-480706-0

Pin	Function	Fuse
1	Main BD "I" terminal	
2	Main BD "S" terminal	
3	Auxiliary BD "S" terminal	
4	NC	
5	NC	
6	Auxiliary BD "I" terminal	
7	Auxiliary BD power, (Aux. Bat.)	F19
8	Main BD power, (Aux. Bat.), ignition switch	
9	BD Relay ground	

J4 - 12 pin Mate-N-Lok Mating Housing AMP 1-480708-0

Pin	Function	Fuse
1	Radio Switch	F16
2	Aux Start Switch	F17
3	Solar Panel	F18
4	L. P. Det. (Aux.)	F15
5	NC	
6	Ground	
7	NC	
8	NC	
9	Fog Lights	F13
10	Aux Start Relay Coil	
11	Ignition Relay Coil	
12	Fog Light Relay Coil	

BATTERY CONTROL CENTER - MINI DIESEL

SERVICE MANUAL

PLUGS - PINS & FUNCTIONS (Cont'd)

J5 - 8 pin Mate-N-Lok Mating Housing AMP 640586-1

Pin	Function	Fuse
1	Step Motor	F3
2	Step Switch	F4
3	L. P. Det. (Main)	F5
4	Ignition Signal	F6
5	Power Seat	F7
6	Rear Heater	F8
7	Power Window	F9
8	Horn/Leveling Jacks	F10

J22 - 2 pin Mate-N-Lok Mating Housing AMP 1-480698-0

Pin	Function	Fuse
1	Isolator Relay Coil Power	F24
2	Isolator Relay Coil Ground	

BATTERY CONTROL CENTER - MINI DIESEL

SERVICE MANUAL

BATTERY CONTROL CENTER

COACH SWITCH PANEL

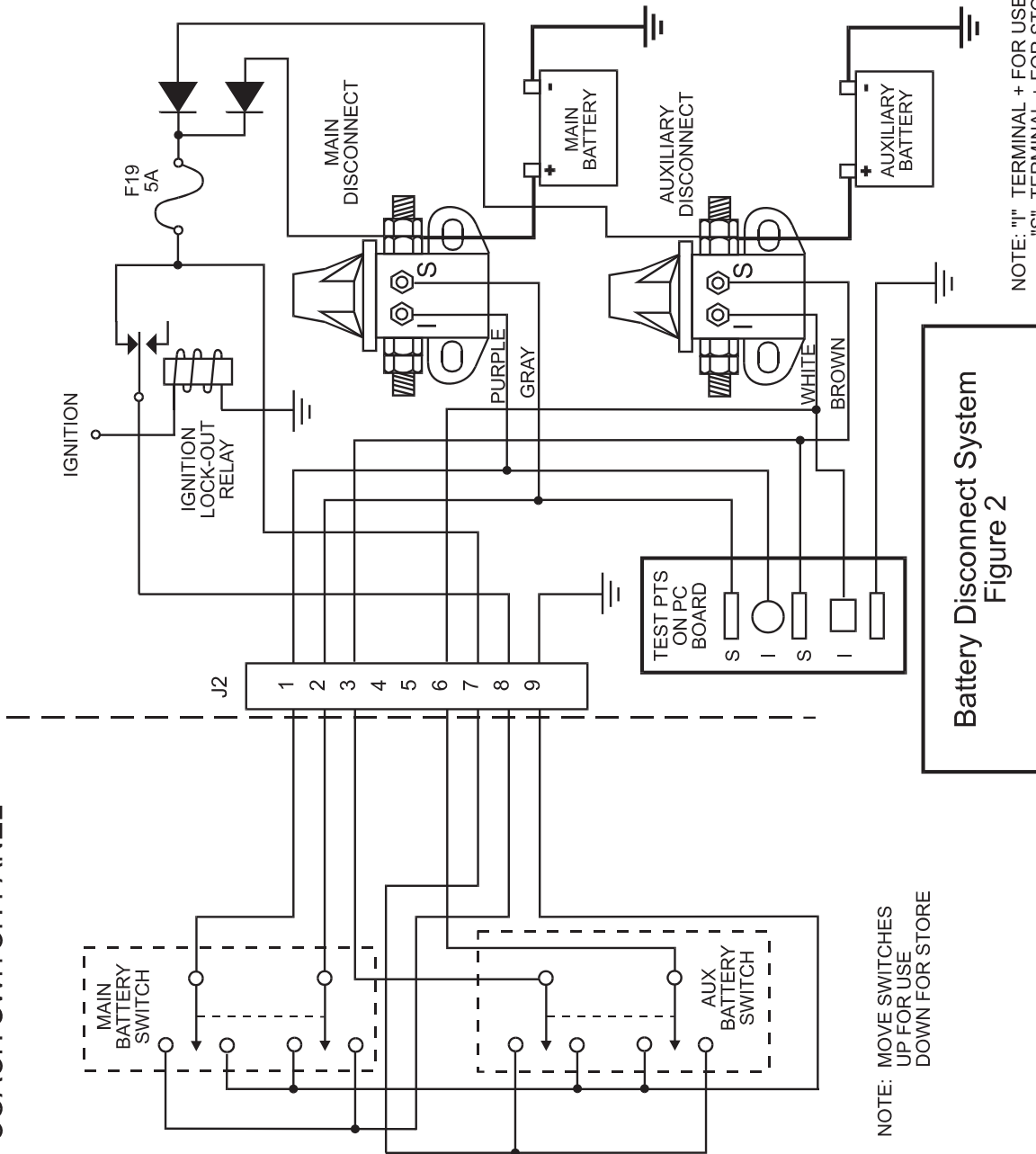

Battery Disconnect System
Figure 2

BATTERY CONTROL CENTER - MINI DIESEL

SERVICE MANUAL

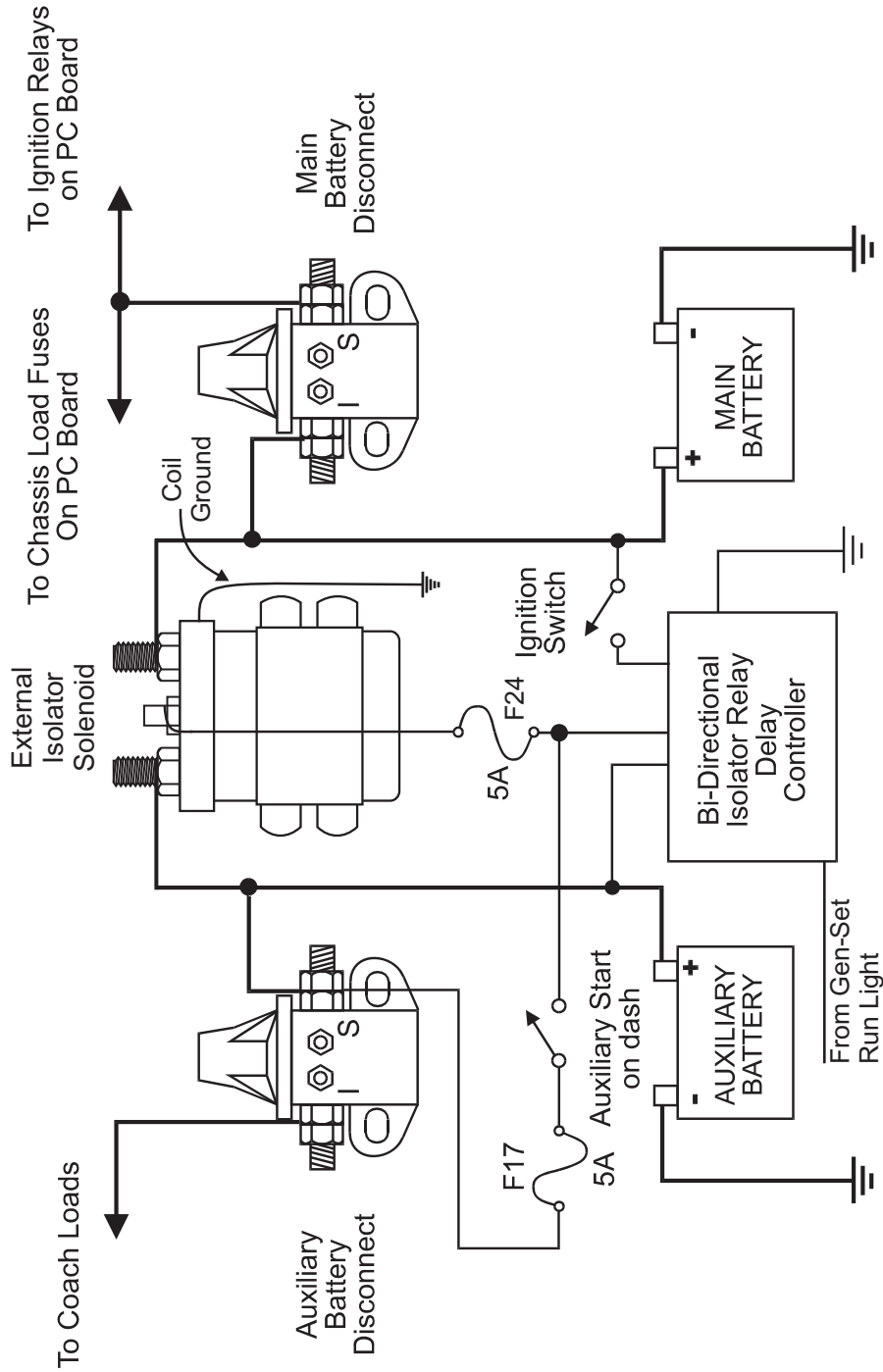

Charging/Auxiliary Start System Figure 3

BATTERY CONTROL CENTER - MINI DIESEL

SERVICE MANUAL

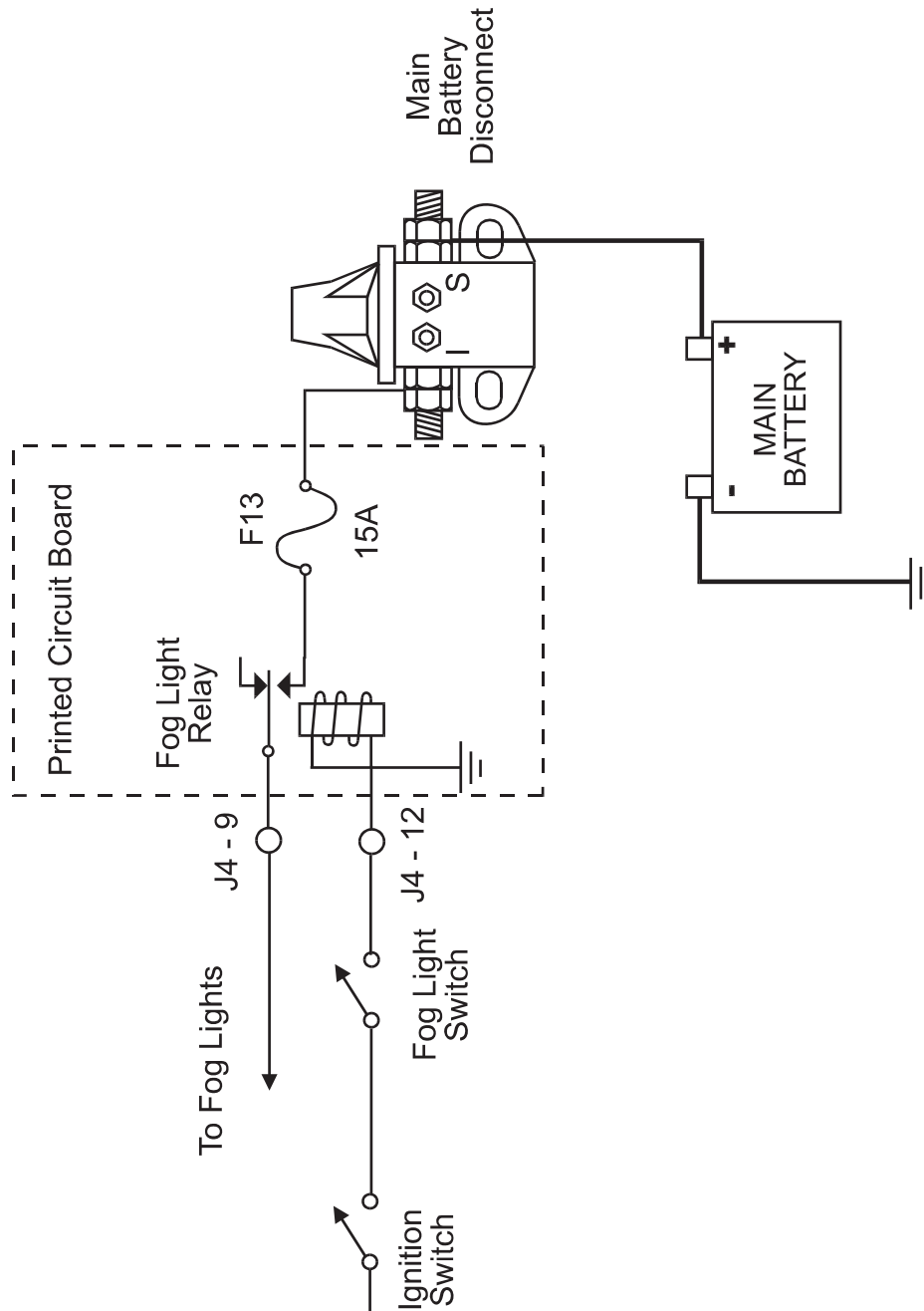

Fog Light Relay
Circuit
Figure 4

BATTERY CONTROL CENTER - MINI DIESEL

SERVICE MANUAL

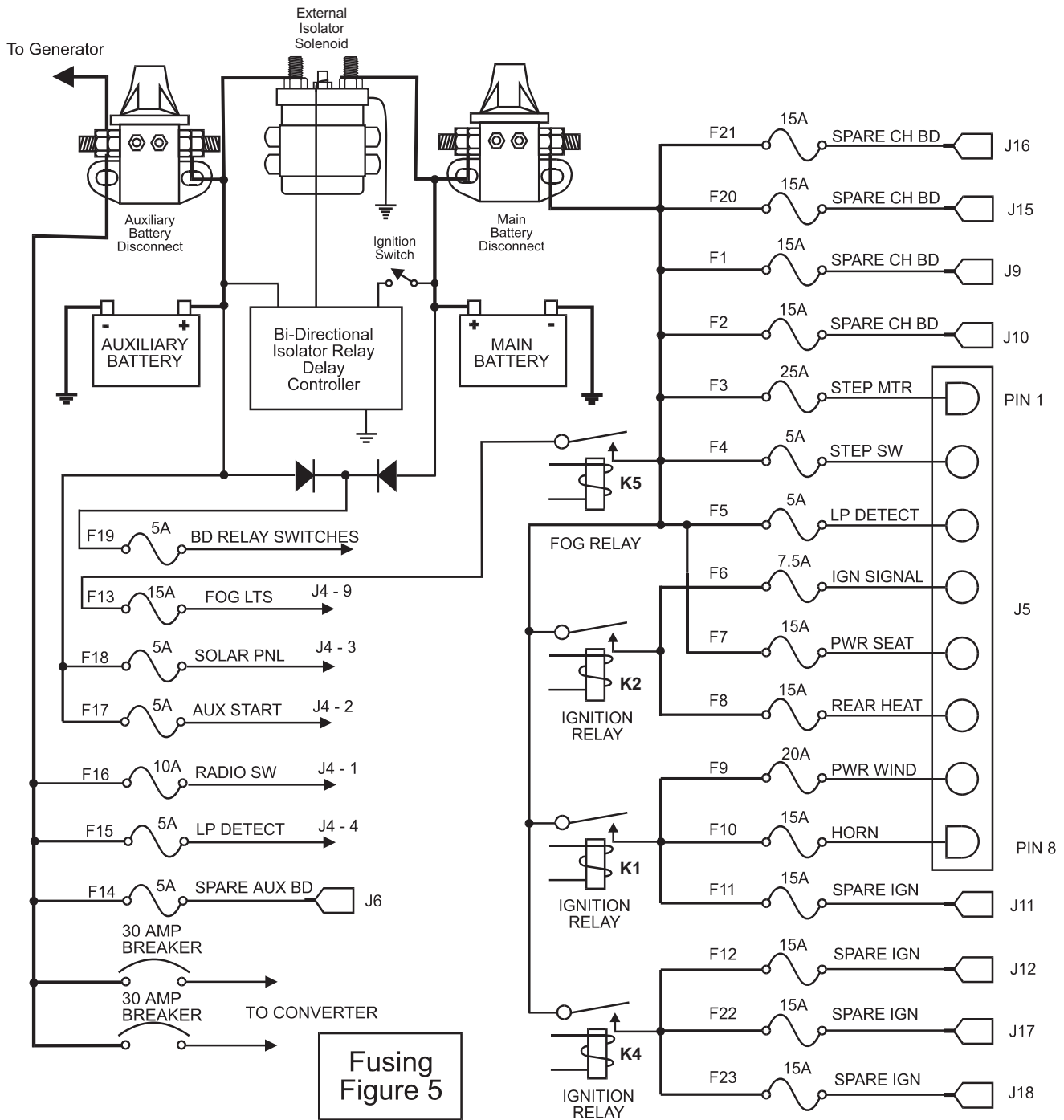

NOTE: Each of the ignition relays is rated at 30 Amps, therefore care must be exercised when substituting fuses or adding additional loads. The sum of the total continuous currents through relay K2, which includes fuse F6 (J5, pin 4)+F8 (J5, pin 6), must not exceed 30 Amps. In like manner, the sum of the total continuous currents through relay K1A which includes fuse F9 (J5, pin 7)+F10 (J5, pin 8)+F11 (J11) must not exceed 30 Amps, and the sum of the total continuous currents through relay K1B which includes fuse F12 (J12)+F22 (J17)+F23 (J18) must not exceed 30 Amps.

Intellitec

1485 Jacobs Rd.
Deland, FL 32724
386.738.7307

BATTERY CONTROL CENTER - MINI DIESEL

SERVICE MANUAL

Intellitec

1485 Jacobs Rd.
Deland, FL 32724
386.738.7307