

# RV SMART BLOCK

## INSTALLATION AND SERVICE MANUAL



Part Number  
00-00920-000



00-00915-000 \*\*  
00-00928-000



00-00929-000 \*\*  
00-00929-100

\*\* non-back lit

**CAUTION:** The full power of the vehicle battery is available at the power input stud on the top of the unit. Service should be performed by a qualified technician.

DO NOT replace fuses of higher rating. This could result in severe damage to the circuitry or create a possible fire hazard.

**Intellitec**

131 Eisenhower Lane North  
Lombard, IL 60148  
630.268.0010 / 1.800.251.2408

# RV SMART BLOCK

## INSTALLATION AND SERVICE MANUAL

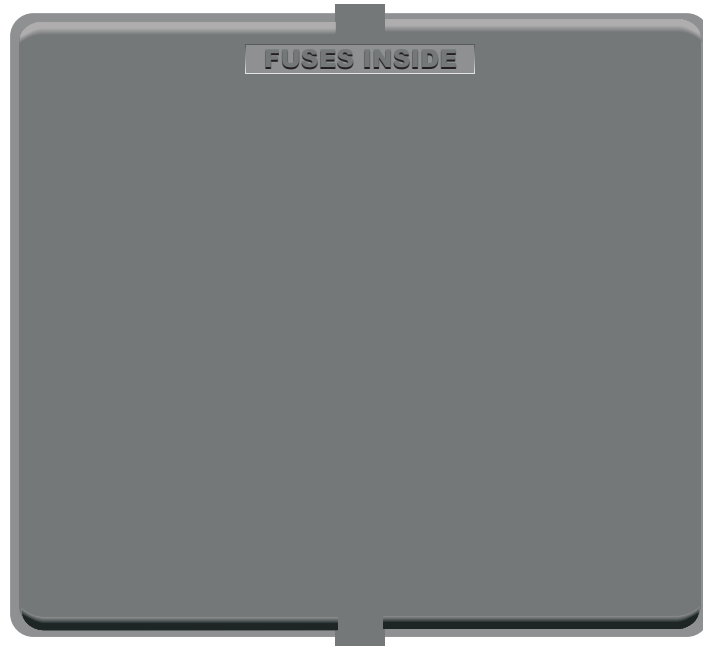

J1-1                  J1-6                  J2-1                  J2-3

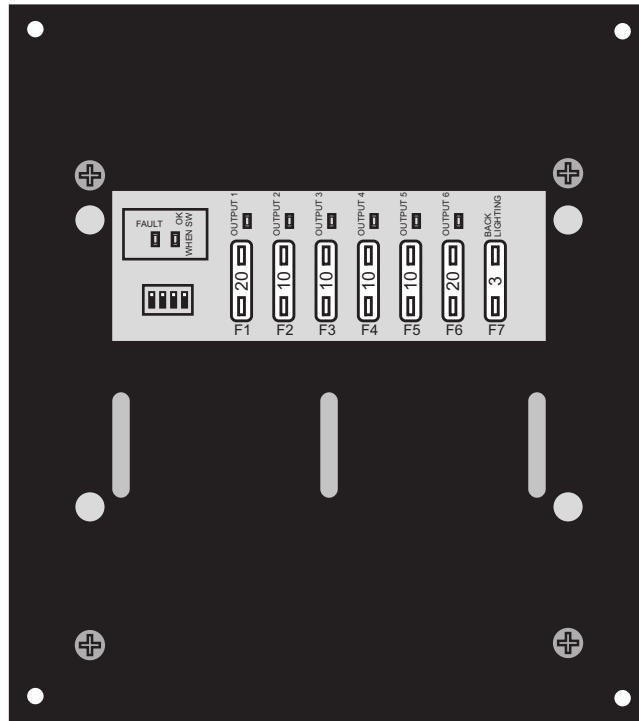

Part No 00-00954-000

**Intellitec**

131 Eisenhower Lane North  
Lombard, IL 60148  
630.268.0010 / 1.800.251.2408

# RV SMART BLOCK

## INSTALLATION AND SERVICE MANUAL

### HOW IT WORKS

The RV Smart Block is used to switch 12 volt DC loads in an RV. It includes six channels of switching, four solid state channels capable of providing dimming and two relay outputs. The various channels are operated from a single pair of wires by momentarily applying a particular value of resistance across these two wires. The resistors can be installed on a switch panel or by using the programming adapters available for the system.

At the press of a switch, the particular channel associated with that resistance will come on; the next press will turn it off. With this scheme, as many switches as desired can be used on the system to switch any channel.

When one of the channels is switched with the solid state output, by pressing and holding the button, the channel will dim the lights connected to that channel. When the button is released, the brightness level will be held. Another momentary press of the button will turn the light off. When the button is pressed again, it will come on to the level it was at when it was turned off.

A dip switch is used to set the dimming capabilities of the four dimming channels. These can be set to be dimming for lighting or non-dimming for loads, such as motors.

Some switch panels may be backlit. There is an output on the module to operate the back lighting. This out will be on when any of the outputs are on. It provides a 12 volt source for the back lighting, limited at 5 amps.

### INSTALLATION

There are two styles of modules available, a surface mount and a flush mount. These modules are electrically identical. The selection of the module depends on the desired aesthetics. The module should be installed in a weather protected area with ventilation to prevent over-heating of the module. There should be at least 3" around the module to provide this ventilation. If the flush mount style is chosen, refer to the cut-out diagram on page 6.

It can be mounted with four #8 screws through the holes in the flanges. Twelve volt power should be brought to the unit with a wire of sufficient size to safely feed all the loads. **Since the maximum current is 60 amps, the minimum wire size should be 6 gauge.** If lighter loads are expected, smaller wire can be used. A suitable ring lug should be crimped on the wire and then attached to the stud.

The loads are connected with a six pin Mate-N-Lok plug at J1. The Communications wires are connected with a three pin Mate-N-Lok plug at J2. The module requires a ground connection through the 1/4" spade lug J3.

### SWITCH PANELS AND SWITCHES

There are a number of switch panels choices that can be used with the module. These include different styles and back lighting options. In addition, conventional momentary switches can be used, in conjunction with *Programming Links*, to activate any channel of the module.

To install the system, the number, style, and location of the switch panels and switches should be determined. Then the number of wires (two for non-back lit and three for back lit) should be selected. The gauge for these wires will depend on the number of switch panels and the total length from the furthest switch panel on a branch, to the RV SMART BLOCK.

**Intellitec**

131 Eisenhower Lane North  
Lombard, IL 60148  
630.268.0010 / 1.800.251.2408

# RV SMART BLOCK

## INSTALLATION AND SERVICE MANUAL

The following table will help determine the gauge.

### MAXIMUM HARNESS LENGTH TABLE

# of Switch Panels	18 gauge wire	16 gauge wire
1	390 ft	625 ft
2	195 ft	311 ft
3	130 ft	207 ft
4	97 ft	155 ft
5	78 ft	125 ft
6	65 ft	104 ft
7	56 ft	89 ft
8	50 ft	78 ft
9	43 ft	69 ft
10	39 ft	63 ft

**Under no circumstances should the total current draw exceed 5 amps.**

### PROGRAMMING LINKS

If a single switch in a given location is desired, a *Programming Link* can be wired in series with any *momentary* switch to activate that channel. (See Typical Wiring Diagram on the last page of this manual) There are six Programming Links available for the system. *One is required for each switch function.* These links are color coded to provide easy identification.

Channel	Color	Part No.
1	Brown	00-00963-100
2	Red	00-00963-200
3	Orange	00-00963-300
4	Yellow	00-00963-400
5	Green	00-00963-500
6	Blue	00-00963-600

### CONNECTOR PIN-OUTS & FUSES

**CAUTION - DO NOT REPLACE FUSES WITH HIGHER THAN LISTED RATINGS.**

This could result in severe damage to the circuitry or create a possible fire hazard.

**J1** 6pin in-line Mate-N-Lok (Mating Housing AMP 640585-1)

Connector Pin	Circuit Function	Fuse Size	Maximum Rating
J1-1	Relay Output 1	F1	Max 20 Amps
J1-2	Solid State Output 2	F2	Max 10 Amps
J1-3	Solid State Output 3	F3	Max 10 Amps
J1-4	Solid State Output 4	F4	Max 10 Amps
J1-5	Solid State Output 5	F5	Max 10 Amps
J1-6	Relay Output 6	F6	Max 20 Amps

**Intellitec**

131 Eisenhower Lane North  
Lombard, IL 60148  
630.268.0010 / 1.800.251.2408

# RV SMART BLOCK

## INSTALLATION AND SERVICE MANUAL

**J2** - 3 pin in-line Mate-N-Lok (Mating Housing AMP AMP 640586-1)

J2-1	Switch Back Lighting	F7	Max 5 Amps
J2-2	MPX Communications Bus		
J2-3	MPX Communications Ground	<b>NOTE: DO NOT USE THIS FOR ANY OTHER CIRCUIT</b>	

### DIP SWITCH SETTINGS

Outputs can be set as dimming or non-dimming. Set 4 dip switches per table.

Position	State	Output	Dimming/Non-Dimming
1	ON	Output 2 (J1-2)	Dimming
1	OFF	Output 2 (J1-2)	Non-Dimming
2	ON	Output 3 (J1-3)	Dimming
2	OFF	Output 3 (J1-3)	Non-Dimming
3	ON	Output 4 (J1-4)	Dimming
3	OFF	Output 4 (J1-4)	Non-Dimming
4	ON	Output 5 (J1-5)	Dimming
4	OFF	Output 5 (J1-5)	Non-Dimming

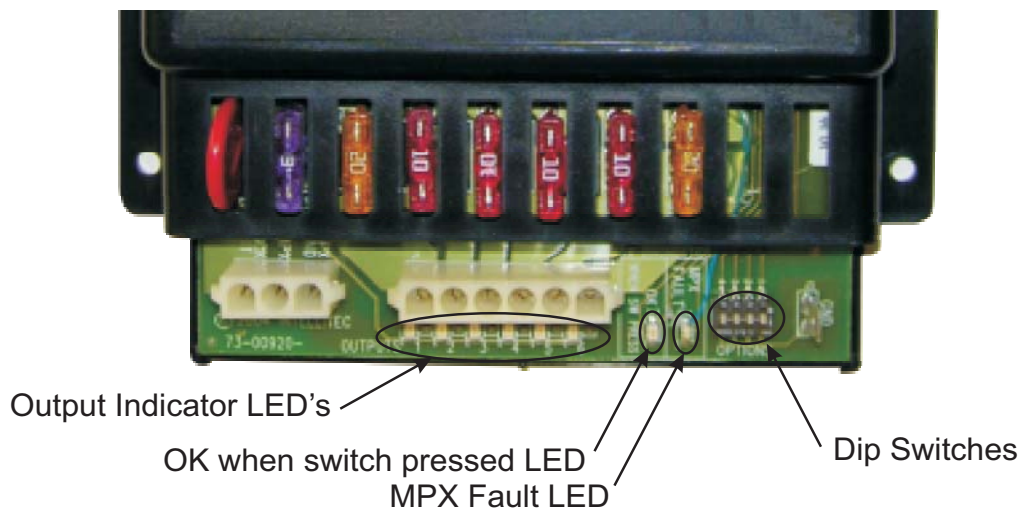

**Intellitec**

131 Eisenhower Lane North  
Lombard, IL 60148  
630.268.0010 / 1.800.251.2408

# RV SMART BLOCK

## INSTALLATION AND SERVICE MANUAL

### TROUBLE SHOOTING

Trouble shooting the system is aided by the eight diagnostic LED's on the module. Six of three LED's are connected to the six outputs, going *ON* when the outputs are on and the fuses are OK. The remaining two LED's are used to diagnose communications and battery voltage problems. The first LED marked "*OK when switch pressed*" will illuminate green when one of the switches is pressed. The second LED marked "*MPX Fault*" will light red if the MPX switch line is shorted to ground or tied to the battery voltage. If the battery voltage should drop below approximately 9 volts for longer than one second, then both the LED's will flash. This indicates the low voltage condition. All outputs will turn *OFF* in the low voltage condition.

# RV SMART BLOCK

## INSTALLATION AND SERVICE MANUAL

### SUGGESTED CUT-OUT FOR FLUSH MOUNT STYLE

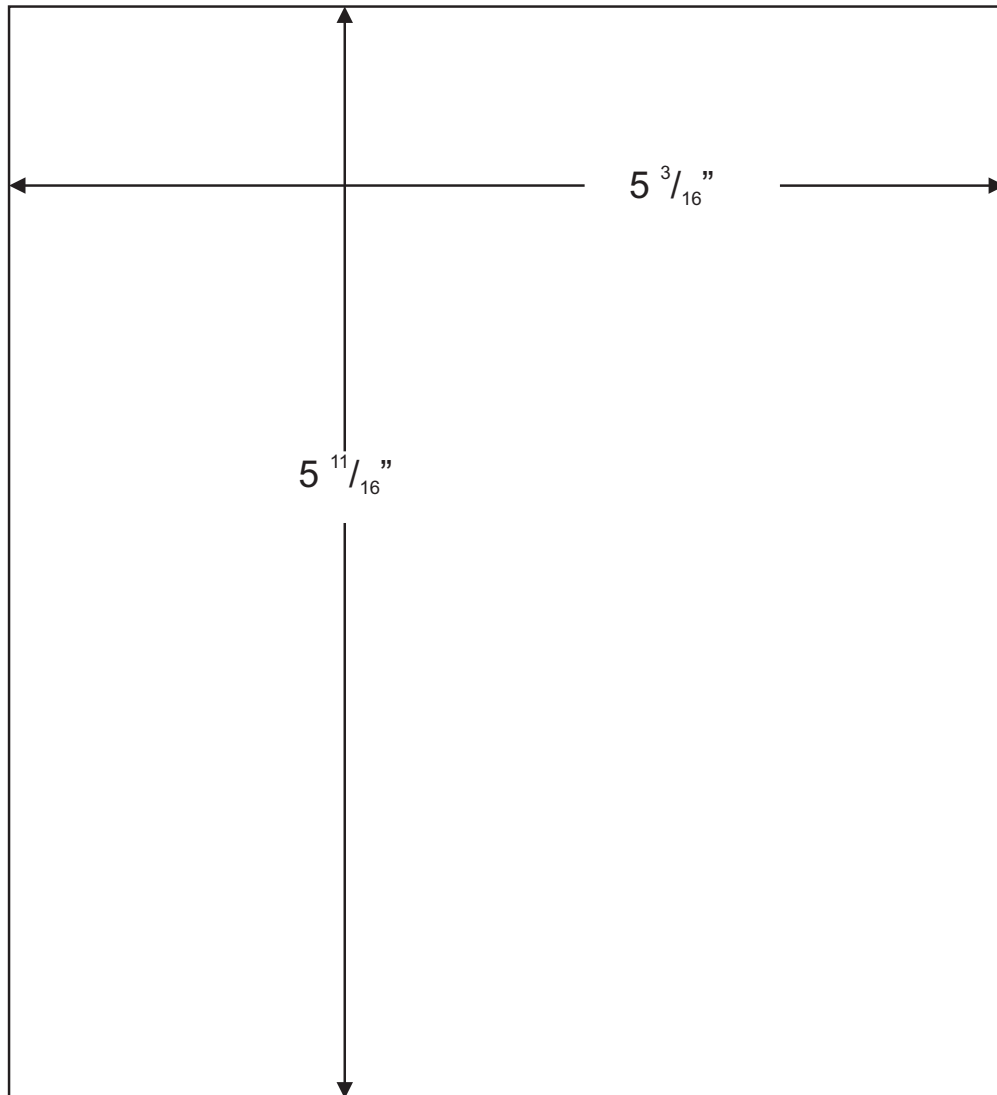

**Intellitec**

131 Eisenhower Lane North  
Lombard, IL 60148  
630.268.0010 / 1.800.251.2408

# RV SMART BLOCK

## INSTALLATION AND SERVICE MANUAL

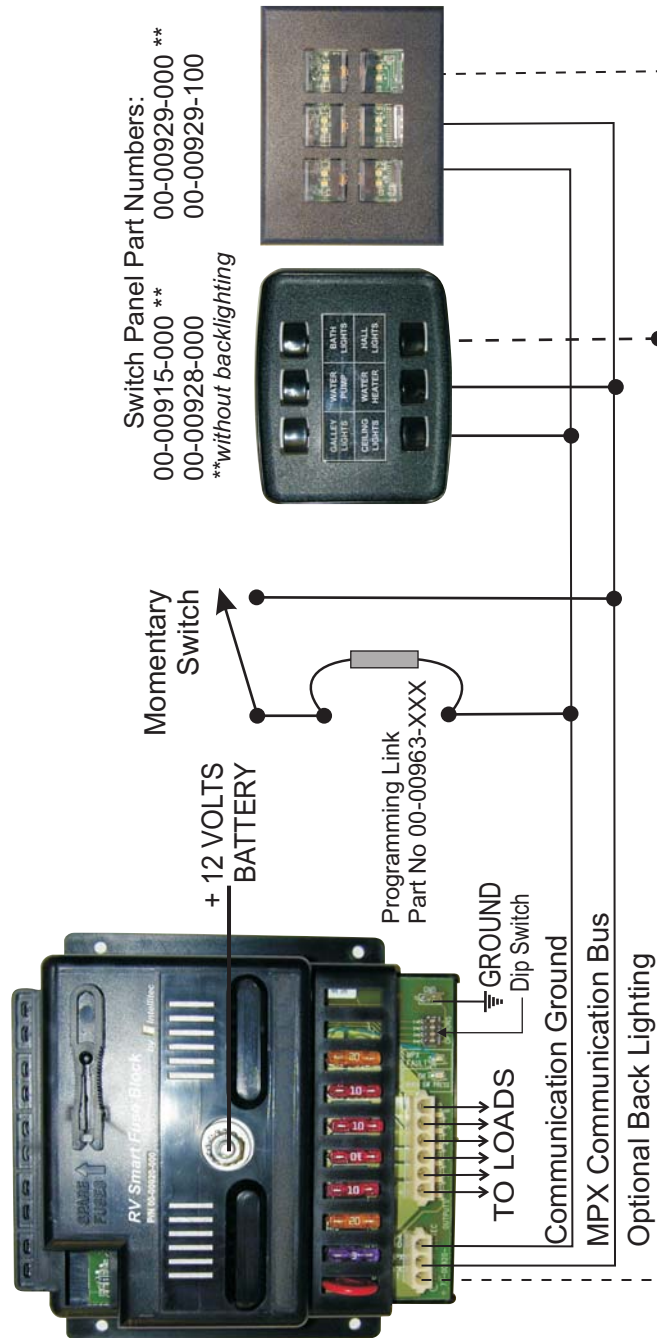

TYPICAL WIRING DIAGRAM