

# ASSEMBLY INSTRUCTIONS FOR REMOTE SWITCH PANEL KIT 01-00979-000

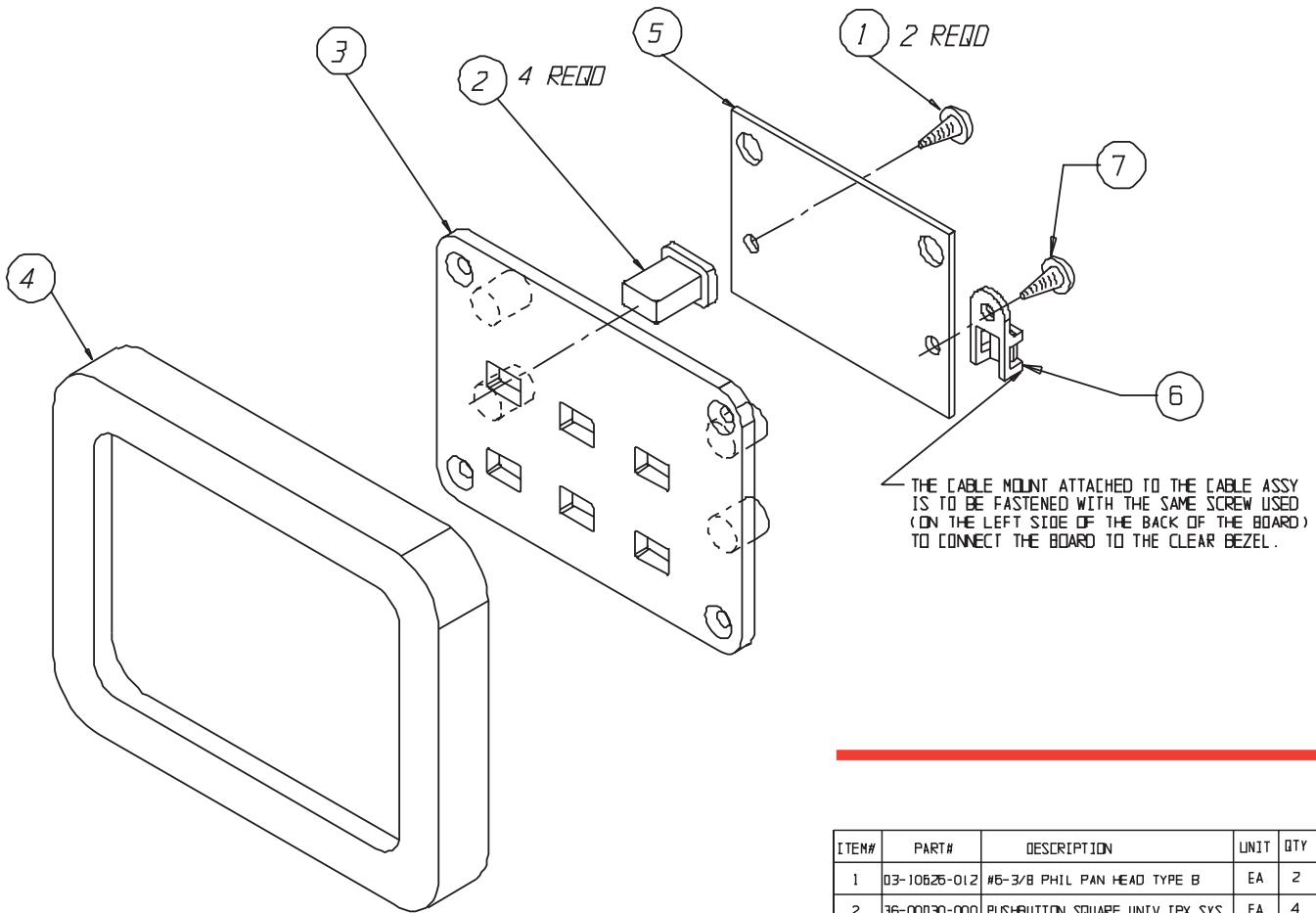

ITEM#	PART#	DESCRIPTION	UNIT	QTY
1	03-10626-01Z	#6-3/8 PHIL PAN HEAD TYPE B	EA	2
2	36-00030-000	PUSHBUTTON SQUARE UNIV IPX SYS	EA	4
3	64-00134-000	BEZEL UNIV 6 BUTTON REMOTE RWK	EA	1
4	64-00210-000	FRAME UNIV 6 BTN RMT W/RND CNRS	EA	1
5	73-00979-000	PCB ASSY 2 TO 4 BTN RMT SW PNL	EA	1
6	05-28001-000	CABLE TIE MOUNT AVERY# 10027	EA	1
7	28-02001-040	TY WRAP 4"	EA	1
8	53-00979-200	ASSY INSTRUCTIONS, 01-00979-000	EA	1



**Intellitec**

131 Eisenhower Lane North  
Lombard, IL 60148  
630.268.0010 / 1.800.251.2408  
FAX 630.916.7890

P/N 53-00979-200 Rev. A 070507