

# Isolator Relays 100 & 200 Amp

**Intellitec's Isolator Relays** are specifically designed to be used to isolate two battery systems. In this application, these relays are required to operate with almost no voltage across their contacts and carry currents ranging from milliamps to hundreds of amps. These relays have been designed and are built to meet these demanding conditions.

The **100 amp Isolator Relay** is designed for most common gasoline engines, while the **200 amp Isolator Relay** is designed for heavier duty applications.

The Isolator Relay provides a simple, reliable, and cost effective means of isolating two battery systems. It is installed between the two batteries, connecting them together for charging. The 100 amp unit can be switched manually through a dash-mounted switch or coupled with one of Intellitec's Isolator controls for fully automatic functioning. The 200 amp version is not a continuous duty unit and requires an Intellitec Isolator - diesel controller to prevent it from overheating when it is used for continuous duty.

A momentary, dash-mounted switch can also be added to provide a "jump start" for the engine, from the auxiliary battery.

---

In a battery charging situation, both batteries may be fully charged and at equal voltages. At that time, there is no voltage across the contacts.



1485 Jacobs Rd.  
Deland, FL 32724  
386 738 7307

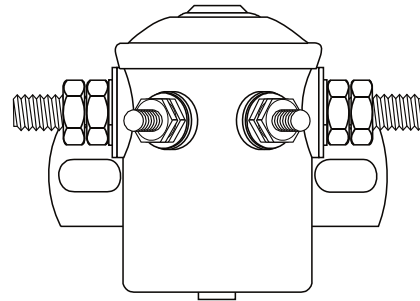

**100 Amp model**

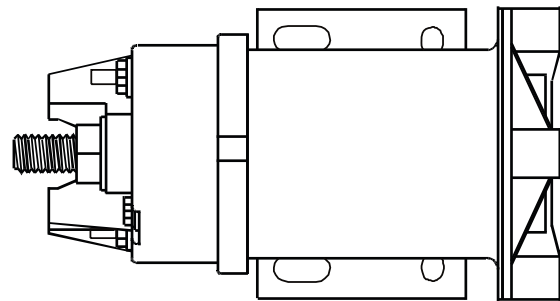

**200 Amp model**

The relay's contacts must close and provide a low resistance without the benefit of any arcing for cleaning. To be sure these relays can perform under these harsh conditions, the contacts are protected with a unique antioxidant coating.

---

In a jump start environment, the relay may have to deliver the full starting current of the engine. These relays, with their heavy construction, can easily deliver the needed current.

The Isolator Relays are ignition protected, so they can safely be mounted in a convenient place near the battery. They can be mounted in any orientation and are immune to harsh shake and vibration found in the vehicle environment.

# Isolator Relays 100 & 200 Amp

Intellitec's new 200 Amp Battery Disconnect relay operates on the same principles as Intellitec's 100 Amp version that has been used by the industry for over ten years. These relays are covered by Patent No. 4,628,289. It is intended to be used in larger vehicles where the continuous current draw can be larger than 100 Amps. This relay can also handle heavy starter currents of large diesel engines.

## Specifications:

Part Number	77-90000-100	77-90000-240	77-90006-120	77-90006-240
Nominal Actuation Voltage	12 Volts	24 Volts	12 Volts	24 Volts
Actuation Current	0.9 Amps	0.4 Amps	6 Amps	6 Amps
Continuous Duty	Yes	Yes	No	No
Minimum Actuation Voltage	9 Volts	18 Volts	9 Volts	18 Volts
Maximum Continuous Carry Current	100 Amps	100 Amps	200 Amps	200 Amps
Maximum Short Term Current (30 Sec)	500 Amps	500 Amps	1200 Amps	1200 Amps
Maximum Ambient Temperature	_____ +85°C _____		_____ +85°C _____	
Minimum Ambient Temperature	_____ -40°C _____		_____ -40°C _____	
Contact Life at Full Load	_____ Minimum of 10,000 Cycles _____		_____ Minimum of 10,000 Cycles _____	

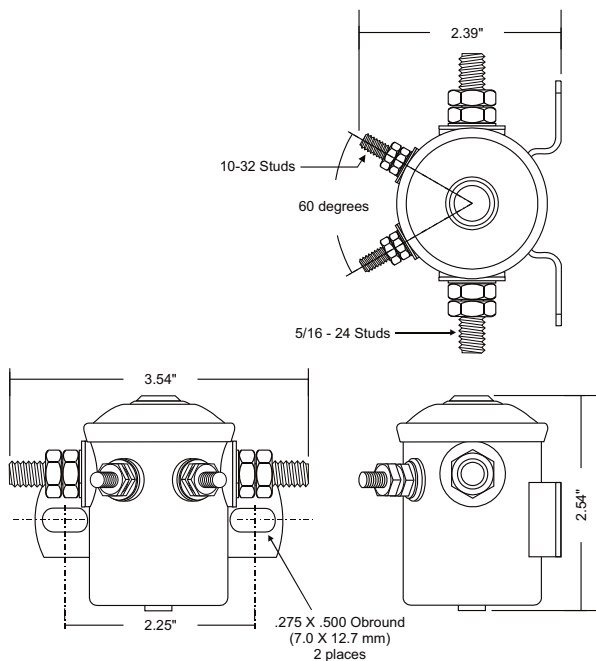

**100 Amp**

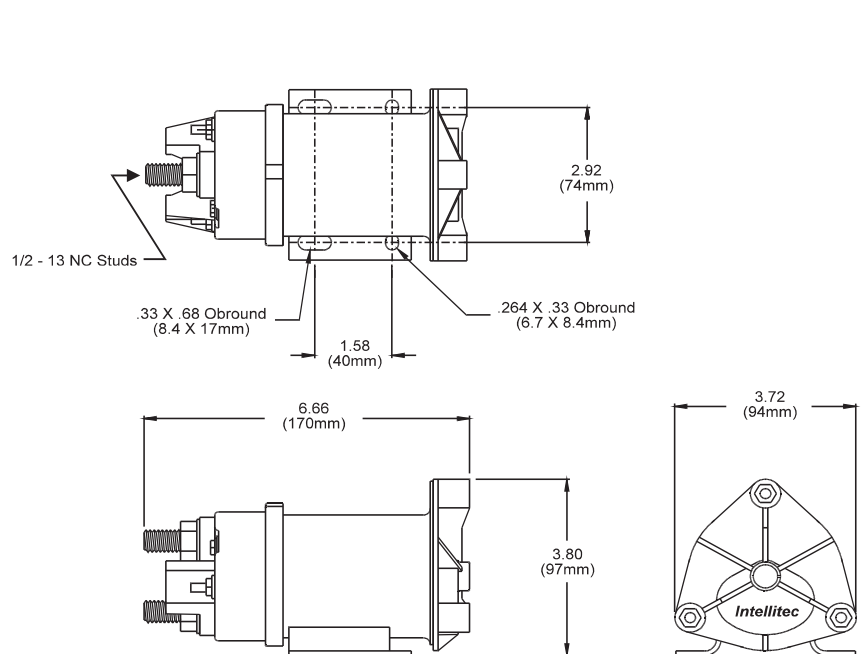

**200 Amp**



1485 Jacobs Rd.  
Deland, FL 32724  
386 738 7307

P/N 53-90000-000 Rev. C 091120