

Bi-Directional Isolator Relay Delay (B.I.R.D.®)



Part number: 00-01136-000



The B.I.R.D.® was designed to make installation simple. With its all in one integrated design, Intellitec brought the electronics to the source, eliminating additional wiring and simplifying the installation process. The B.I.R.D.® has a mounting plate attached with two mounting holes located in the back and uses automotive standard connectors for peripheral connections.

These instructions contain all the information needed to help you install the Battery Disconnect. It is assumed the installer has basic skills in electrical wiring, mechanics, and carpentry. If you have any doubts about these techniques or instructions consult with someone BEFORE you connect a wire or cut a hole.

Wire Diagram 1

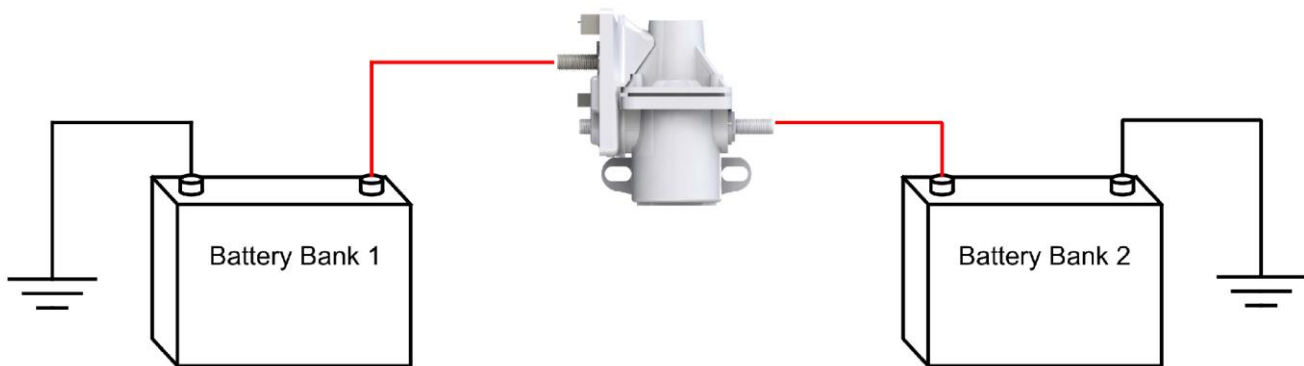

Wire Diagram 1 illustrates the primary connections of the B.I.R.D.®. 5/16" bolts are used for both battery supplies and are capable of supporting 100A of current.



Wire Diagram 2

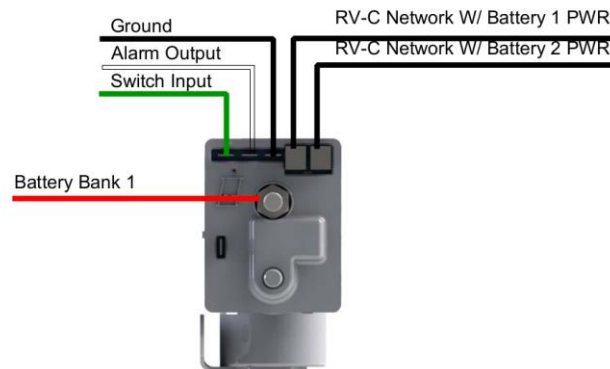

Wire Diagram 2 illustrates the additional connections on the B.I.R.D.[®]. Note that the second battery connection is on the opposite side of the device.

Application Connections:

Signal	Function	Connection Type
Switch Input (GND)	Aux Start allows extra cranking power for starting the vehicle	0.25" Quick Connect Female
Alarm Output (VBAT)	350 mA output indicating isolation and bridge condition	0.25" Quick Connect Female
Ground	Ground supply for B.I.R.D. [®]	0.25" Quick Connect Female
RV-C Network Source 1	RV-C communications with source 1 power	4 pin Molex Mini-Fit
RV-C Network Source 2	RV-C communications with source 2 power	4 pin Molex Mini-Fit
Battery 1 Positive	Battery 1 source connection	5/16" Ring Term
Battery 2 Positive	Battery 2 source connection	5/16" Ring Term

RV-C Connectors:

The RV-C network connections use 4 pin Mini-Fit connectors and follows the RV-C standard pin-out convention described in section "2.1.4 Connectors" of the RV-C guideline.

Pin Number	Description
1	CAN H
2	CAN L
3	PS1 -
4	PS1 +

Pin Number	Description
1	CAN H
2	CAN L
3	PS2 -
4	PS2 +



Locating the B.I.R.D.® Aux Start Switch:

The B.I.R.D.® offers a direct switch input signal that allows the user to bridge the two batteries together for extra cranking power when necessary. This can become very useful if the chassis battery is low or depleted and the vehicle cannot be started. The switch should be readily accessible by the user. This switch not only controls the state of the isolator relay but also provides indication of the state and whether faults have occurred. Ensure the wall used for mounting the switch has enough clearance behind it to allow cables access. Typically, ¾" to 1" is required.

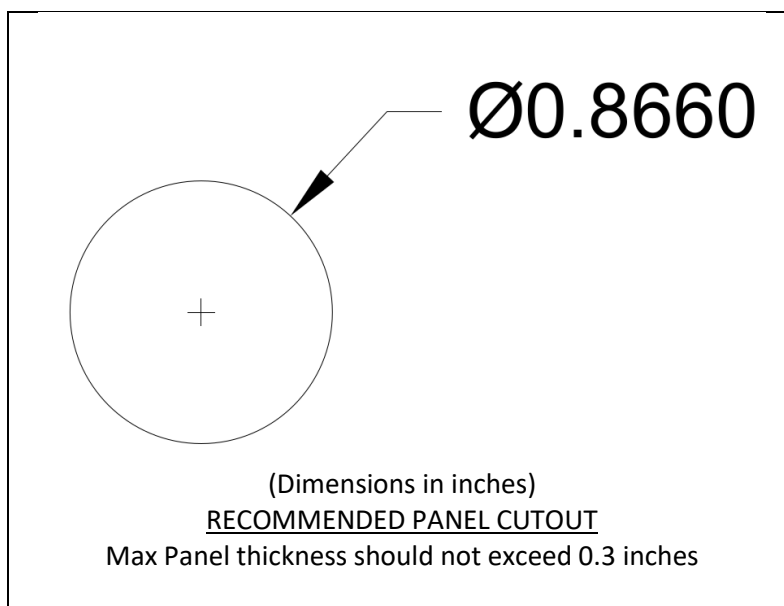

Note: Drawing dimensions refer to the switch used in the Intellitec kit (part # 10-01136-000).

Installing the B.I.R.D.®:

WARNING: Before proceeding, disconnect all sources of power. Unplug the shore power cable and turn off the generator. Disconnect the battery(s) negative (-) terminal.

The B.I.R.D.® controls a relay that acts as electro-mechanical switch that disconnects the battery. It should be located near the batteries for wiring simplicity. When installed, the relay will be inserted "in-line" between the two battery banks positive (+) terminals. Keep this in mind when choosing the installation location.



While holding the relay in place near the battery banks, mark the location of the two holes for the relay mounting bolts. Set the relay aside, and drill two mounting holes. Before bolting the relay in place, route the Control Cable near the mounting place. When installing in an engine compartment, be sure to provide sufficient space for airflow to allow for cooling.

Connecting the Cables:

WARNING – Torque requirements for the high-power copper contact studs should be 5 – 7 FT-LBS, not to exceed 9 FT-LBS. When connecting the battery positive wires, you must use two wrenches to tighten the nuts on the stud, one to turn the outside nut and one to hold the nut on the inside from turning. The copper stud must not turn, or relay operation may be affected.

Locate the positive battery cable for the chassis and coach battery bank. Carefully cut the cable near the relay. Strip the cable insulation back about 1/2" on each end and crimp on the battery cable terminals defined in the Application Connections table. Remove keps nuts from both copper studs and connect the terminals to the copper studs on the relay.

If using the provided B.I.R.D.[®] Switch Harness Kit (10-01136-000), follow Wire Diagram 2 for matching the wire harness colors to the connectors.

The B.I.R.D.[®] has 2 RV-C ports. One of these ports provides battery source 1 power while the other provides battery source 2 power. This feature offers a more advanced network management option. Refer to Wiring Diagram 2 to ensure proper connection of the RV-C network.

After all wires have been connected and tightened properly, reconnect the batteries negative cable.

Verifying Operation:

To verify the B.I.R.D.[®] is powered up, check for the green LED heartbeat on the device. This will illuminate right above the company logo.

If using the provided switch with the Intellitec kit 10-01136-000 toggle the state of the disconnect. If the LED ring on the switch is illuminated then the isolator relay is closed, if the LED ring on the switch is not illuminated then the isolator relay is open.

When using this device in an RV-C network use the DC DISCONNECT DGN to change the state of the isolator relay. Refer to the 53-01136-300 - Integrators Guide for specific information regarding status and control of the B.I.R.D.[®].



Available Product Literature and Guides:

Brochure:	53-01136-000
Product Specification:	53-01136-001
User's Guide:	53-01136-100
Installation and Applications:	53-01136-200
Integrators Guide:	53-01136-300

Contact Information: www.intellitec.com

Intellitec Products, LLC 1485 Jacobs Road, DeLand Florida, USA 32724
(386) 738-7307

