

Road Commander Low Current Module

Part number: 00-01095-000



Description:

The Road Commander LC Module provides control for turning interior and exterior lights on and off. The Low Current, LC, module has four available output channels rated at 5 Amps each. The maximum current draw from the LC module under full load is 20 Amps. The LC module has 8 high/low selectable inputs which can be used to control its own outputs or various outputs on other Road Commander modules. The module outputs are driven utilizing self-protected FET technology to protect the module and the output load. Apart from the self-protecting FET shutdown the module has configurable current shutdown which can be set up to 5 amps. These outputs are ideal for lighting circuits as they are PWM controlled and can dimmed down to 10% duty cycle.

The Low Current module may be used as a 'stand-alone' component module, as part of the Intellitec Programmable Multiplex Control System 'PMC', or as part of the Road Commander system. The manual details the Low Current module operation in each of these applications. There are no serviceable parts within the Low Current module. If the module is deemed defective then it must be replaced. Disassembly of the module voids the warranty.

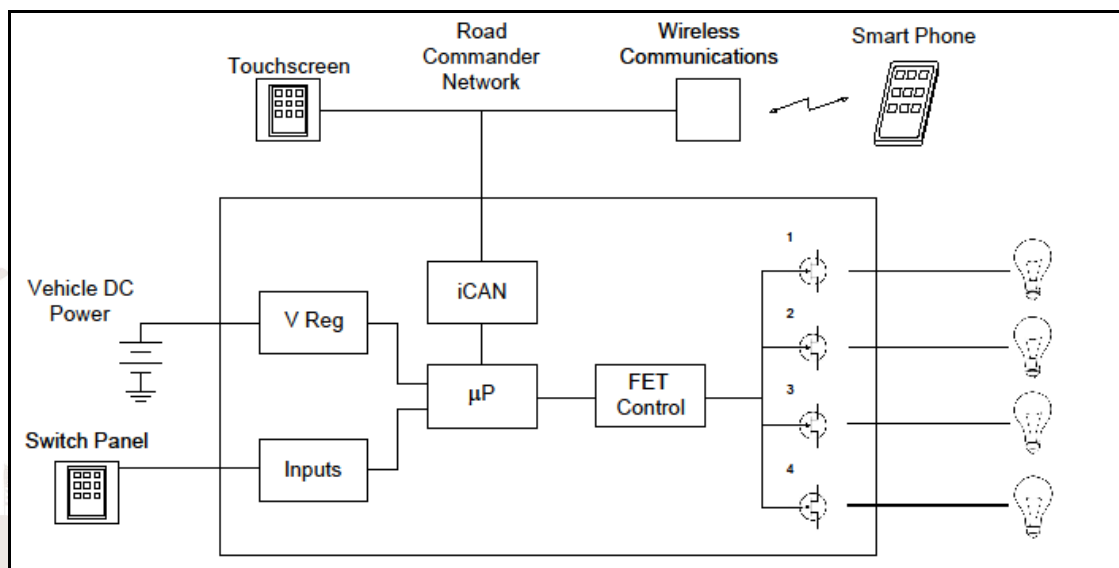

Typical Arrangement – Lighting Control Interface



Product Features

- 'Sleep mode' minimizes the amount of power consumption when inactive for certain amount of time.
- FET outputs provide 'Over-current ' protection for each output. No additional fusing required.
- PWM controlled FETs allow Module to dim lights.
- Perfect for 'dry camp' operation. Allows the freedom of changing what is on without entering your coach or towable model.
- On-board indicators show network status and fault codes.
- 8 configurable inputs and outputs allow for unique application customization.
- Control is available by using OEM installed switches, Intellitec touchscreen LCD panels, and SMART Devices.
- Expandable and adaptable to previous model year coaches.

Environmental Specifications

Operating temp: -40/50 deg C (-40/122 deg F)
 Storage temp: -40/125 deg C (-40/260 deg F)
 Intrusion Rating: None
 Agency approvals: None

Electrical Specifications	Unit	Min	Typ	Max
Operating supply voltage	V	10	12	20
Reverse supply voltage	V			-36
Max Current Draw	A			20
Quiescent Current Draw	mA			50
Control Current (Per Output)	A	0		5
Control Circuit Voltage	V	10	12	30
Logic Input Voltage	V	0	12	20

Mechanical Specifications	Unit	L x W x H
Housing:	Inch	6 x 3.6 x 1.2
	mm	152.6 x 90.7 x 38.6
Module Weight:	ounces	8
	grams	227



Harness: Pig-tail and/or terminator part number
 Configurator Adapter Harness 11-01095-018
 18-way Wiring Pig-tail (J1) 11-01095-118
 RC Network Terminator 11-01095-218

Connector(s): Faston - Battery
 J1, 18-way Molex Mini-Fit Jr.

1	N/C	7	Input 4	13	RS232 TX
2	CAN H	8	Input 5	14	RS232 RX
3	CAN L	9	Input 6	15	Output 1
4	Input 1	10	Input 7	16	Output 2
5	Input 2	11	Input 8	17	Output 3
6	Input 3	12	DC Ground	18	Output 4

Available Product Literature and Guides:

Brochure: 53-01095-000
 Product Specification: 53-01095-001
 User's Guide: 53-01095-100
 Installation and Applications: 53-01095-200
 Supporting Documents: 53-01095-300

Available Accessory Items and Kits:

USB Program Adapter Kit: 10-01079-000

Contact Information: www.intellitec.com

Intellitec Products, LLC 1485 Jacobs Road, DeLand Florida, USA 32724

(386) 738-7307