

AUTOMATIC ENERGY SELECT SWITCH

SERVICE MANUAL

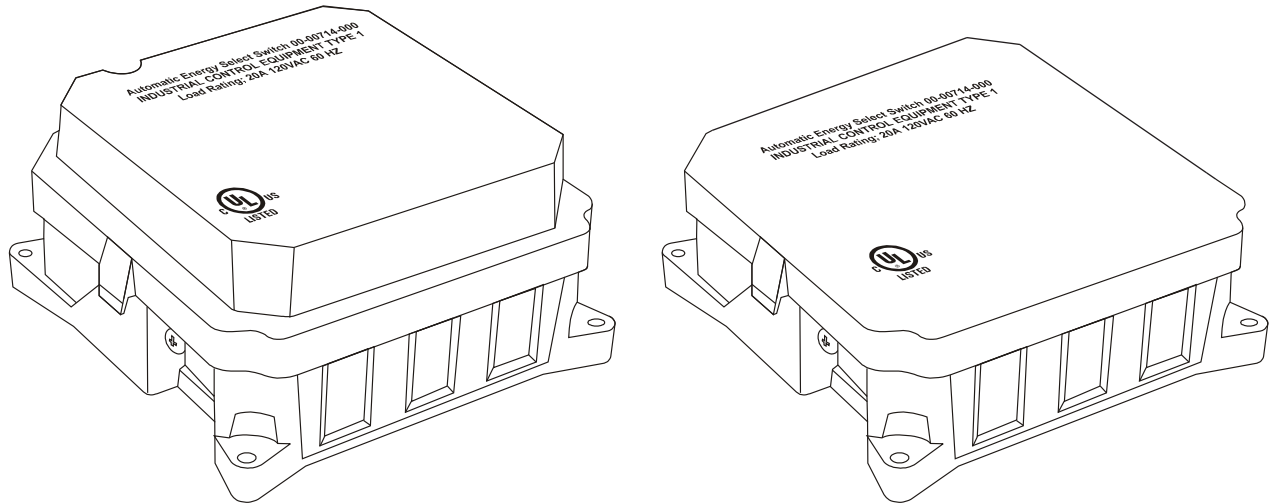

Part No. 00-00714-000 / 00-00714-100

Intellitec's **Automatic Energy Select Switch (AESS)** is designed to be used in RVs to share the power available from a single circuit breaker between two large loads (up to 20 amps). The **AESS** applies power to both appliances until the primary load draws current. It then removes power from the secondary load to prevent the circuit breaker from being overloaded. This function is particularly useful for sharing power between the microwave oven and another "sheddable" or postpone-able appliances, such as the washer/dryer, or water heater. Typically, this function was performed with selector switches, forcing the owner to manually switch between the two appliances.

WARNING:

The Automatic Energy Select Switch operates from shore power cord. Lethal voltages are present inside this box. Before removing the cover, be sure the coach is disconnected from shore power and the generator is not operating.

All servicing of this box should be done only by a qualified Service Technician.

Tools required: Line voltage test light, AC voltmeter

Intellitec

1485 Jacobs Rd.
Deland, FL 32724
386.738.7307

AUTOMATIC ENERGY SELECT SWITCH

SERVICE MANUAL

HOW IT WORKS

The **AUTOMATIC ENERGY SELECT SWITCH (AESS)** senses the current drawn by the primary or "on demand" load and controls the power to the secondary or "shed-able" load. When the power is initially applied, and the primary load is drawing less than 3 amps, power will be supplied to the secondary load after an initial 45 second delay. If the primary load draws more than 3 amps, power to the secondary load will be removed and held off until 45 seconds after the primary load is off.

SERVICING THE UNIT

There are no serviceable components in this unit. If it is not working, replace the entire unit. To remove the cover from the unit, remove the screw at the center bottom of the cover. Before removing the screw, be sure all power is off. Gently lift the latches on either side of the cover and remove it. The connections to the unit will all be visible. (See Figure 1.) Remove all six wires from the board. The board can be removed from the box by removing the two mounting screws.

WARNING:

The Automatic Energy Select Switch operates from shore power cord. Lethal voltages are present inside this box. Before removing the cover, be sure the coach is disconnected from shore power and the generator is not operating.

All servicing of this box should be done only by a qualified Service Technician.

Tools required: Line voltage test light, AC voltmeter

Hi-POT TEST:

At the installers preference, to assure there are no potential shorts, a Hi-Pot test can be performed on the installation. If installing a 00-00714-000, the black lead from the Secondary Load must be moved to the terminal with the black lead to the primary load. If installing a 00-00714-100, no wires need to be adjusted.

The Hi-Pot test should now be conducted in accordance with standard procedures for the tester being used. Assuming the system passes, if installing the 00-00714-000, the cover should be taken off and the lead moved back to its normal connection point. If not, the problem must be corrected before proceeding further.

Intellitec

1485 Jacobs Rd.
Deland, FL 32724
386.738.7307

AUTOMATIC ENERGY SELECT SWITCH

SERVICE MANUAL

Installation Instructions:

- 1) Ensure power to the breaker panel is off.
- 2) Take off unit lid by removing screw and expanding clips on either side.
- 3) Feed wire from breaker panel through left most strain relief on side of enclosure.
 - a. Ensure enough cable is pulled through to allow for wire stripping and routing.
- 4) Cut back outer insulation, exposing white, black and green wires.
- 5) Strip insulation of white, black and green wires.
- 6) Insert black wire into screw terminal location marked as "LINE" on the PCB.
- 7) Torque screw terminal of wire per product data sheet.
- 8) Insert white wire into left most screw terminal location marked as "NEUT" on the PCB.
- 9) Torque screw terminal of wire per product data sheet.
- 10) Move green wire out of the way temporarily.
- 11) Feed wire from secondary load through middle strain relief on side of enclosure.
 - a. Ensure enough cable is pulled through to allow for wire stripping and routing.
- 12) Cut back outer insulation, exposing white, black and green wires.
- 13) Strip insulation of white, black and green wires.
- 14) Insert black wire into screw terminal location marked as "LOAD2" on the PCB.
- 15) Torque screw terminal of wire per product data sheet.
- 16) Insert white wire into middle screw terminal location marked as "NEUT" on the PCB.
- 17) Torque screw terminal of wire per product data sheet.
- 18) Move green wire out of the way temporarily.
- 19) Feed wire from primary load through right most strain relief on side of enclosure.
 - a. Ensure enough cable is pulled through to allow for line wire (black) can be fed through current sense loop then into screw terminal as shown in datasheet.
 - b. Black wire will be longer than white and green wires.
- 20) Cut back outer insulation, exposing white, black and green wires.
- 21) Strip insulation of white, black and green wires.
- 22) Insert black wire into screw terminal location marked as "LOAD1" on the PCB.
- 23) Torque screw terminal of wire per product data sheet.
- 24) Insert white wire into right most screw terminal location marked as "NEUT" on the PCB.
- 25) Torque screw terminal of wire per product data sheet.
- 26) If installing 00-00714-000 units, insert each of the green wires into the open terminals of the neutral bar and torque screws to torque requirement as illustrated in datasheet.
- 27) If installing 00-00714-100 units, use provided wire nut or Wago connector to tie green wires together.
- 28) Organize wires such that the lid can be installed back onto unit.

AUTOMATIC ENERGY SELECT SWITCH

SERVICE MANUAL

Trouble Shooting

The Select Switch is a simple circuit which senses the current of the primary load and utilizes a relay to switch the secondary load, if the primary load draws more than 3 amps.

Problem

Possible Cause/Solution

Neither load will operate.

The circuit breaker in the distribution box for the loads is tripped. Reset the circuit breaker.

Both loads are turned off. Check the switch settings of the loads.

The secondary load will not operate.

The secondary load may be turned off. Check the switch settings of the secondary load.

The AESS is defective.

AUTOMATIC ENERGY SELECT SWITCH

SERVICE MANUAL

00-00714-000 ILLUSTRATED

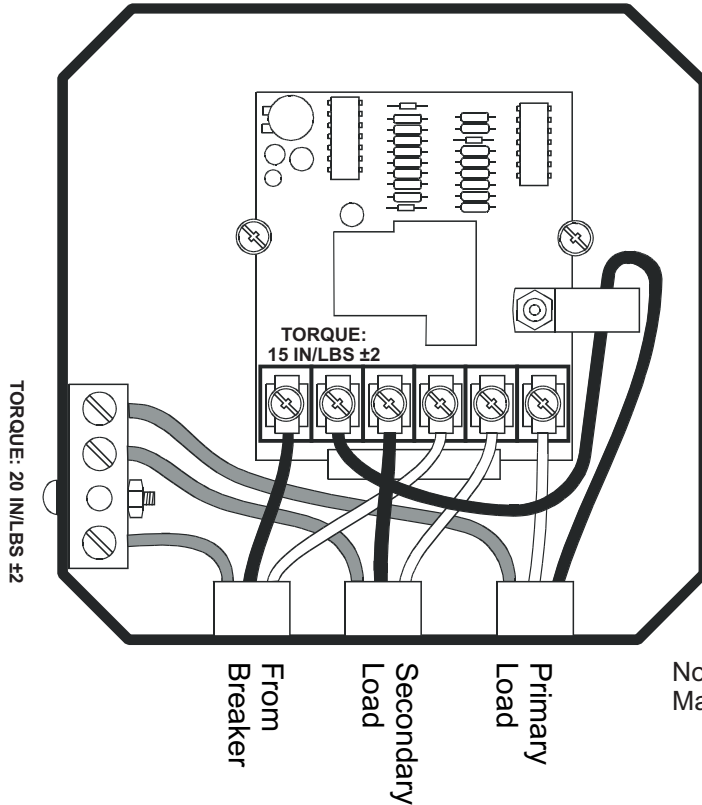

View with cover removed
Figure 1

Note: Wire Nut or Alternative Connector May Be Used in Place of Neutral Bar

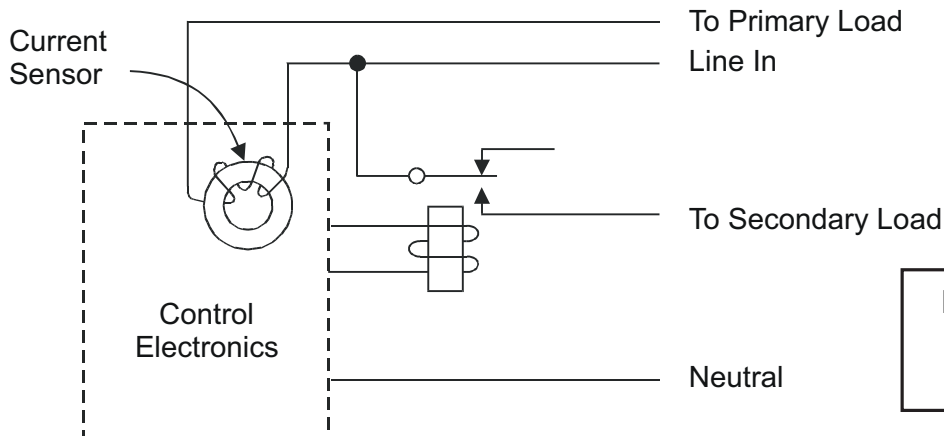

Equivalent Circuit
Figure 2